

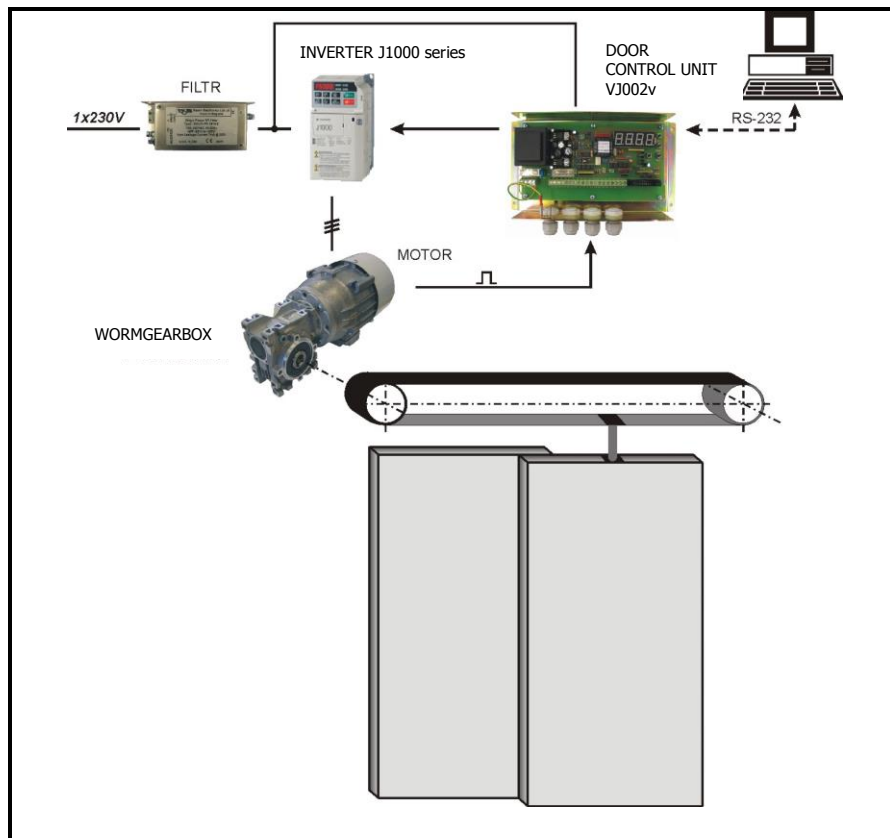

SLIDING DOOR DRIVE



Instruction manual

Installation and setting manual

Producer: Somati system s.r.o.
Jihlavská 510/2c
664 41 Troubsko, okr.Brno - venkov
Tel.: 547 427 011
Fax: 547 427 013
E-mail: export@somati-system.cz
www.somati-system.cz





CAUTION

The sliding door drive 1RM1 and its modifications should be installed only by appropriately electrotechnically qualified personnel.

The sliding door drive 1RM1 and its modifications should be installed only by personnel thoroughly acquainted with functions of the whole drive unit as well as with its components, especially with inverter J1000 series and with lift door control unit VJ002v.

The instruction manual of the inverter Varispeed J1000 is an integral part of the instruction and setting manual of 1RM1.

Wiring of 1RM1 should be performed only when inverter and lift door control unit are turned OFF.

Do not touch inverter inside equipment nor connected devices and elements for two minutes after power supply disconnection. The frequency inverter includes the DC bus capacitor, which is still charged and can be dangerous for certain time after the power supply was disconnected. Wait until the red CHARGE LED is extinguished.

Wiring of 1RM1 drive components should be performed only according to connection diagram presented in this manual. Different wiring may result in improper, unreliable and also dangerous function of the door as well as in damage or destruction of some drive components.

Setting the parameters of VJ002v unit and inverter Varispeed J1000 should be performed only after thorough acquaintance with function of the whole drive unit and also with drive components. Wrong setting of some parameters, especially inverter parameters, can cause dangerous door function!

Maximum closing speed needs to be limited with respect to door weight and to requirement of objective standards that relates to maximum kinetic energy.

Pay attention to correct setting of the inverter V/f pattern – constants **E1-01 – E1-10**. Size of closing and opening forces and size of currents, especially at low speed, depend on the correct setting of the V/f pattern. Correct setting influences the proper function of the whole 1RM1 drive.

In case of obscurity please contact your supplier.





List of documentation:

1 WIRING EXAMPLE	1
2 MECHANICAL INSTALLATION	2
3 ELECTRICAL WIRING	3
3.1 Input/output connection diagram of VJ002v	4
4 REFERENCE SEARCHING	5
4.1 Motor phase conductors matching	5
4.2 Reference searching without limit switch.....	5
4.4 Reference searching via limit switch	6
5 OPENING	6
6 CLOSING	8
7 OVERLOAD EVALUATION	10
7.1 Evaluation by speed difference	10
7.2 Evaluation by current excess	10
8 PUSHING IN END POSITIONS	11
9 END POSITIONS REGULATION	11
10 SIGNALS TO DOOR CONTROL SYSTEM	11
11 IMPORTANT CONTROL AND DSETTINGS INVERTER COMPONENTS AND CONSTANTS	13
11.1 V/f pattern	15
11.2 Ramps and S-curve pattern.....	16
11.3 Programmable inputs S3, S4	16
11.4 Over-torque detection.....	16
11.5 Overload detection - IOL.....	16
11.6 Fault Diagnoses.....	17
12 SET 1RM1	18
13 PROGRAMMABLE RELAY ZEN	23
14 PERIODICAL INSPECTIONS	25
14.1 Inverter	25
14.2 Cabinet.....	25
14.3 UPS – required user maintenance.....	25
15 CIRCUMFERENTIAL SCHEMATICS	26
15.1 Power supply	26
15.2 Power unit	27
15.3 Frequency converter circuit	28
15.4 Door unit	29
15.5 Programmable relay	30
15.6 Controls	31
15.7 Photocell, flashlight (signalization).....	32
15.8 Signalization of door status	33
15.9 Cabling 1	34
15.10 Cabling 2	35
15.11 Cabling 3	36
15.12 Sensor connection for the drive 1RM1.....	37





1 WIRING EXAMPLE

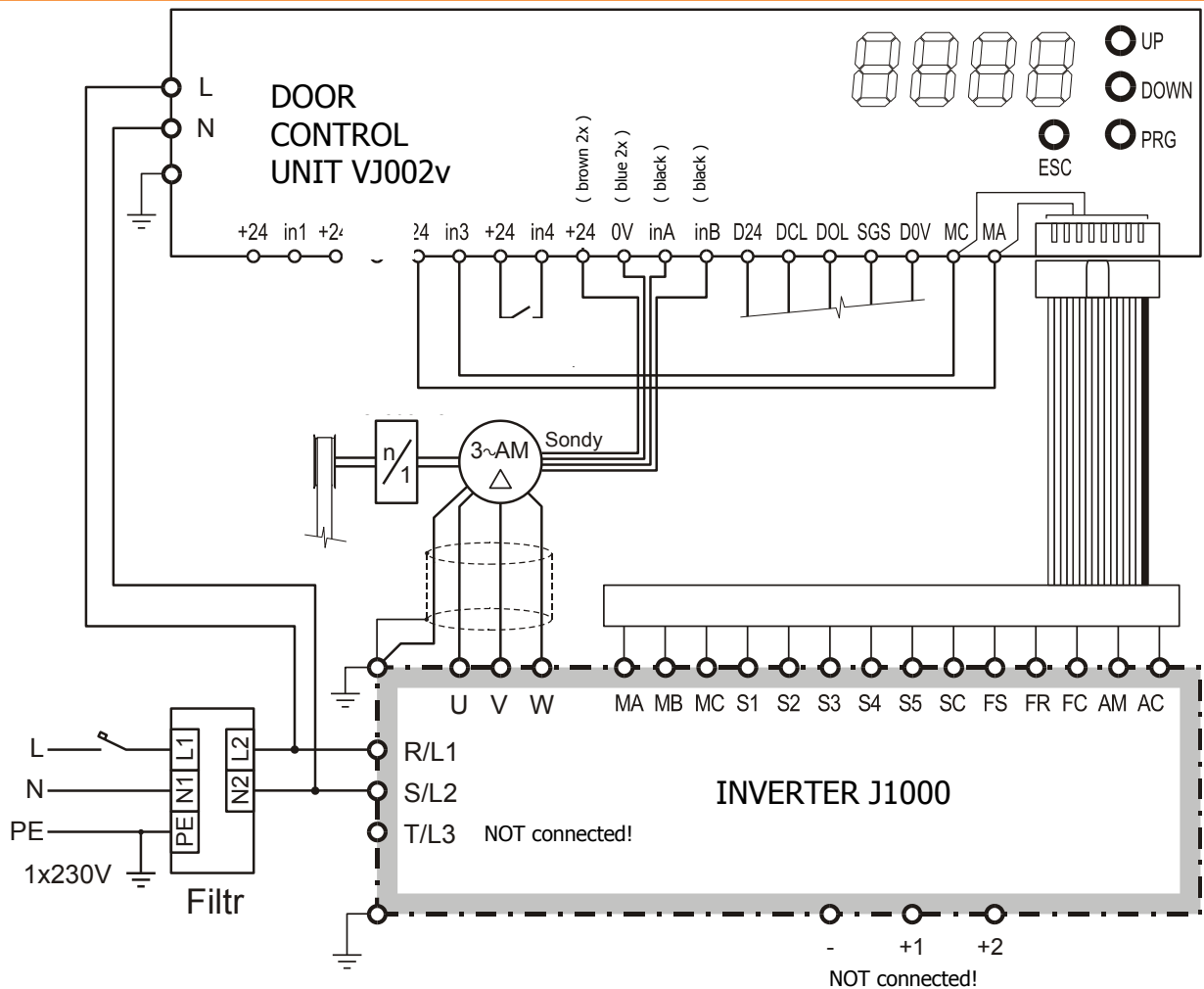

1. The wiring of control parts should be performed with flexible wires with wire thickness 0,5 mm²!
2. At wiring of noise filter follow the rules to achieve the proper function of input noise filter, especially
 - minimum wiring distance between filter and inverter
 - minimum impedance of the earth wire on the PE terminal of the noise filter
3. Ground leakage current of the filters 3G3JV-PFI1010 and A1000-FIV1010 is c. 20 mA. In case of using the ground-fault interrupters in lift protection system with sensitivity amperage·30 mA, disconnection of them can occur, especially when the inverter power supply is switched ON. We recommend using filters with small ground leakage current in case of using the ground-fault interrupters.
4. Connection of probe pulse sensor
 - brown power supply +24 V to +24
 - blue ground terminal to 0V
 - black PNP output to the terminals inA and inB
5. Sensors numbering: By looking at the motor from motor blower side and at clockwise rotation the sensor A precedes the sensor B.





6. In dependence on the drive mechanical organization the lift door control unit VJ002v, inverter and motor should be verified and their phase conductors correctly matched in order that the door must be closing when the terminal S1 is switched ON and the position reading must be decreased. S. Paragraph 4. Reference searching.
7. **Interconnect 0V of VJ002 and ⊕ of inverter for proper function!**
8. Use the 16A circuit breaker for the short-circuit protection of the 1RM1 power supply.
9. We recommend placing the circuit breaker or switch fuse near VJ002V for an easy and safe disconnection from the network in case of the reset VJ002V and converters when you set up parameters.

Manual setting of the VJ002v constants

Setting buttons functions:

ESC	Return from programming mode to operating mode. If the changed value is not confirmed by PRG button in programming mode, the change is not saved.
PRG	Programming mode – display of a constant type. Display of the selected constant content. Storage of the constant change.
UP	Go to next constant. Increasing of the constant value.
DOWN	Go to previous constant. Decreasing of the constant value.

Setting and alignment of the drive via PC – s. Program documentation. The program enable to further saving parameters on the disk, creating of type parameter sets and trace - scan the desired course and the actual speed of the door.

Setting of the VJ002v constants

2 MECHANICAL INSTALLATION

Install the mechanical part of the drive – motor gearbox with the pulley on the lift doorframe.

Mount the timing belt, ensure its initial tension and check the smooth door running by mechanical opening and closing. Door running must be smooth not only without rub but also without skip of the timing belt.

Respect maximal allowed gearbox radial load in dependence on distance between pulley and gearbox.





3 ELECTRICAL WIRING

Perform the wiring of electrical parts of the drive carefully. Pay attention to reliable connection of earth terminals of the motor, inverter, lift door control unit and noise filter.

Verify and eventually correct basic initial setting of the inverter and lift door control unit for given door model. Recommended values for door dimensions 3m and 6m are in Table 5.

When you change some parameters of converter (such as the value U / f curve) the drive must be in Stop mode - in the absence of startup signal. If enabled Refilling in the end positions (: SPS = 1) are startable signals to the inverter still present and converter is to be put into stop mode by pressing STOP (red). Converter starts indicate a fault: STOP key with startup signal with double flashing LED on key RUN. Parameters can be changed now. After the changing of converter parameters, the converter must be unblock:

- disconnecting the inverter from the network. Remember to safe and accessible disconnecting drive 1RM1 of the project at el. part of the drive.
- reset VJ002V such as disconnecting from the network or by using PC (key F121) without disconnecting from the network.

CAUTION

Wrong (too high) setting of the inverter constants **E1-05, E1-08, E1-10** can result in high motor torques and inadmissible high door forces, which can cause personal injuries or damages of door mechanical parts.

After power ON to VJ002v the microprocessor self-test and test display of all segments of 4-position LED display (c 5 sec) is always performed and then the operation reference searching starts – motor rotates at the speed set in SREF towards to closing and position reading is decreased.

Display of negative value of the position:

- for value from 001 to 999 by minus sign before the number
- for value from 1000 to 9999 by decimal point behind the number





3.1 Input/output connection diagram of VJ002v

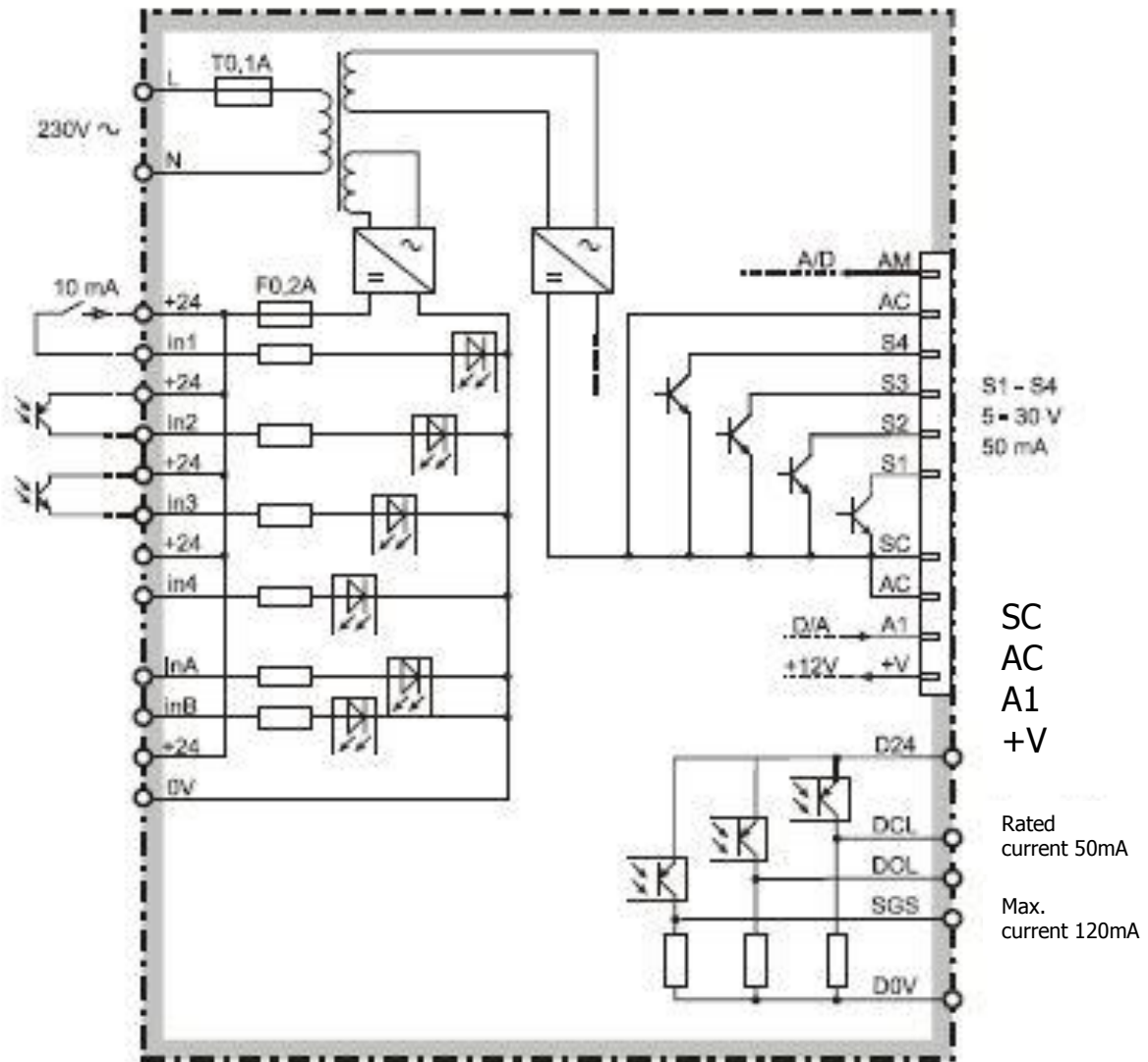

Addition: Relay output

RO DCL DOL SGS

Can be ordered only with the required relay

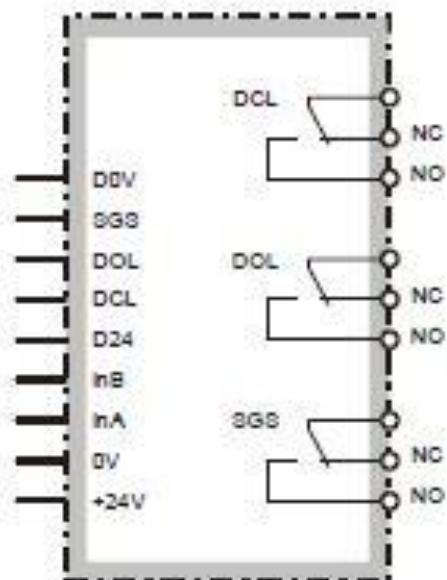



4 REFERENCE SEARCHING

Every time after connections of power supply to VJ002v the operation of searching of referential door position CLOSED is started.

4.1 Motor phase conductors matching

At reference searching operation the terminal S1 of VJ002v is switched ON and the door must be closing. In case of reverse direction of rotation change the wiring of two phases of the motor or of the inverter output, or terminals S1 and S2 of inverter or of VJ002v.

During the door closing the position reading must decrease. If not, change the sensors A and B.

We recommend performing the matching of motor phase conductors without the belt mounted.

4.2 Reference searching without limit switch

VJ002v sends out the command „close” – by switch ON of S1 terminal at the speed given in **SrEF**. When the door reaches the end position CLOSED (speed decrease below 2%) the counter is cleared and VJ002v goes over to operation mode according to constant setting and control command IDC.

If there is in the reference search mode to activate the signal IOL – overloads signal from the converter (over current values set in **L6-02** % of the nominal motor current **E2-01**, S1 immediately turns off, converter has given zero speed and failure is reported No .2 – and VJ002V is blocked). To unlock and continuation of the activity - repeating a search operation VJ002V reference must be reset by disconnecting from the network or to adjust the PC by using appropriate command (F12).

To verify proper function of reference searching is suitable to start this mode from the situation when the door is fully or partly opened.

Make sure that the door reliably reaches the end position CLOSED by several performances of reference searching operation.

If the parameter value **CtrF** = 1, in search of reference is taken into account photocell signal LIB and signal STOP, when **CtrF** = 0 signals STOP and LIB are respected.

The speed **Sref** is set enough high (20-25%) to the gate with confidence overcome all passive resistances to the end position CLOSED. We recommend checking the motor current on the keypad. The value in the reference search mode is ranges from 0,9 to 1,A according to the V / f curve converters and values **Sref**. Values outside of this range indicate incorrectly set U / f curve or a fault in the motor or mechanism of the door.

All frequency setpoints = speeds are given in% of maximum frequency (**E1-04**) and given the inverter in the form of an analog signal.

If one of the signals of probes dysfunctional of mechanical damage sensing system, power failure, etc., VJ002V is locked and writes the fault No.7. If both sensing probes are broken, there will be a door stop and reset the counter in any position of the door.

The fastest verify of probe condition is the watching the flashing LED on the rear of the probes at slow rotating the engine. If the probe does not light when covering the diaphragms tooth may be faulty sensors supply - 24 V to VJ002V, a large distance probe from the sensing disc, broken wire, etc.





4.4 Reference searching via limit switch

By using the sensor of the end position CLOSED the door is closing until the +24V signal from sensor comes. In case of attendance of this signal in the moment of power ON to VJ002v, firstly the door is opening, after loss of signal "closed" +50 pnd direction is changed to closing until the +24V signal is regenerated.

In case that the limit switch SDO is switched ON during the opening without switching OFF of SDC, the error No. 6 is displayed and operation is blocked.

Speed value S_{REF} should be set high enough, so the door reliable overcomes all passive resistances up to the end position CLOSED.

All values of frequency reference (= speeds) are determined in % of maximum frequency (**E1-04**) and are entered to inverter as an analog signal.

5 OPENING

Opening diagram

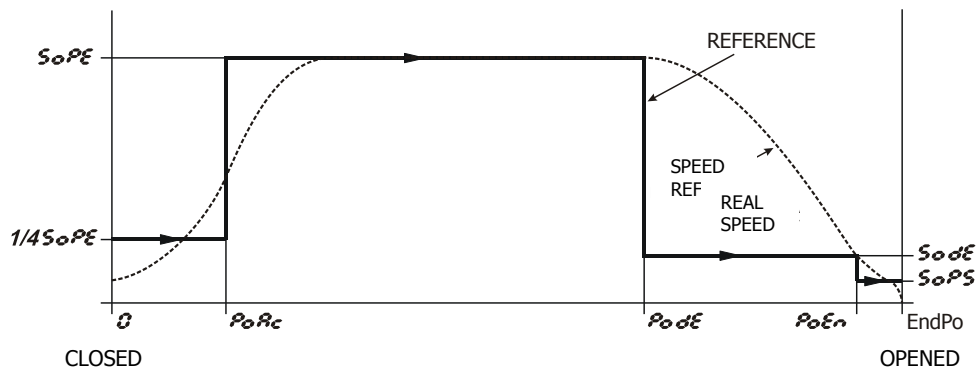

After coming of opening signal the reference $1/4 \text{ SoPE}$ is given to inverter (acceleration speed), in **PoAC** point is changed to **SoPE** (opening speed), in **PodE** point to **SodE** (opening deceleration speed) and in **PoEn** point or eventually after switch ON of limit switch SDO the operation of stopping in the end position is initialized – at **iSPS** = 1 the reference **SoPS** for pushing in opened status is given, at **iSPS** = 0 the reference 0 is given and the terminals S1 a S2 are switched OFF.

SoPE maximum of opening speed according to requested opening process. In the event of complete failure of the speed sensors from the beginning of the opening is ensured that the door start moving max. speed $1/4 \text{ SoPE}$.

SodE opening deceleration speed: at this speed the door must securely overcome mechanical resistances during opening, but it cannot be too high, by reason of elimination of mechanical noise at mechanical doorstop. Typically set of 20% in choosing of the maximum frequency **E1-04** = 50 Hz. The strength of on the driving speed is then best defined by setting the mean value of the output voltage **E1-08**, which we recommend to adjust the frequency - inverter parameter **E1-07**.

SoPS at this value of reference the current of inverter in the end door position cannot exceed 0,3 - 0,4 A. Higher current values result in inadmissible warming of the motor, higher "inverter noise of the motor" and danger of damage of motor or inverter. Value of the current is checked on inverter display. In case of setting of **SoPS** less then minimal frequency value in **E1-09** the internal signal start do not go through the inverter and inverter output is switched OFF in spite of attendance of starting signals on terminals S1 or S2.





PoAc switch point on the maximum opening speed **SoPE**...

PodE switch point on speed deceleration on opening. It sets with regard to the selected maximum speed of opening **SoPE** and deceleration ramp **C1-02** and the value of S-curve **C2-03** and **C2-04** so that the door reached the deceleration rate **SodE** before the end position OPEN and commuted to the end position defined speed **SodE**. **The appropriate setting of this parameter has a significant effect on the course of opening.** Too high setting has the effect that the gate runs to end position open at a higher speed than **SodE**, low settings then causes the extension of the opening, as the doors will commute to the open position speed **SodE** longer distances.

PoEn switch point on pressure speed in the open position. **This point gives practical point stop for gate in the open position.** Gates execute from the point **PoEn** only track the slowdown of the speed values **SodE** down the ramp on the **C1-02**. Point **PoEn** must be at least 1-5 cm less than the maximum dimension of the door the mechanical stops. In case of setting too close to the maximum size or even higher, there is no safe switch to pressure speed **SoPS** and flows into the engine high current applications **SodE**, which is not permissible in terms of warming the engine and the converter and may cause damage to the converter or motor.

Recommendations

1. Determination of dimensions - width of the door

To determine the switching points you need to know the maximum size of the door in pnd. This can simply be identified as follows: After the end of operation referencing the closed position and reset the counter to VJ002V make sure the gate is actually in the closed position (not remained not closed properly due to impurities in the track gates, etc.) and turn off converter by pressing the red STOP. Mechanically open the gate to end position open. Value of the display VJ002V indicates the dimension of gate in pnd. Converter is most easily unblock again by resetting VJ002V – disconnecting from the network VJ002V or command form the PC.

2. Test of reliable gate opening in operation

Correct setting of the leveling speed **SodE** and power of the door = center output voltage **E1-08**. Try it in reliable operation of the door. Stop the gate manually in the final stages of opening – in dimension of **PodE**. When released the gate must reliably tightened to the open position – dimension **PoEn**. We recommend to set **SodE** 20 % for the maximum frequency **E1-04** = 50 Hz. Medium voltage **E1-08** = 60 V to 66 V.

Due to incorrect setting or mechanical effects will stop the drive between dimensions PodE and PoEn, for more than 10s, control passes to the pressure, is registered error No.8, but the gate are ready for the next operation.

In case that the IDC signal is changed to go close during opening, the operation is controlled by set operation mode.

According to the parameter values **ctol** is or is not in the evaluation function of overloading speed difference.





6 CLOSING

Closing diagram

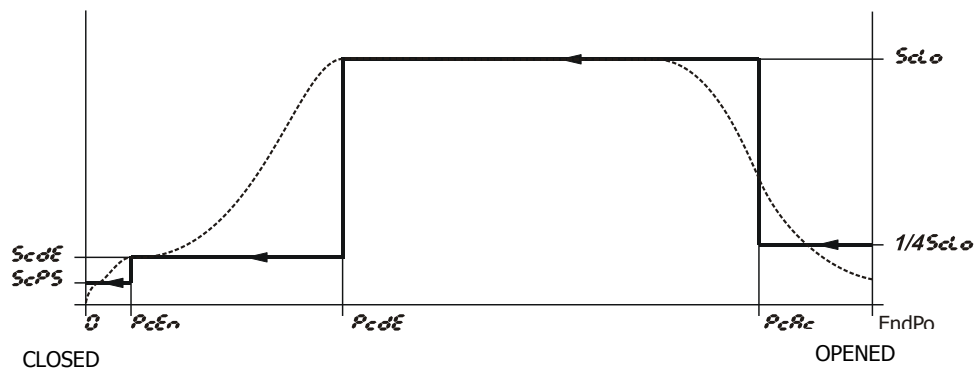

After coming of closing signal in the end position OPENED the closing is started by giving reference $\frac{1}{4} \mathbf{ScLo}$. In **PcAC** point the reference is changed to **ScLo** (closing speed). In **PcdE** point the reference is changed to **ScdE** (deceleration closing speed). In **PcEn** point the reference **ScPS** for pushing in the end position CLOSED is given.

ScLo maximum of closing speed according to requested closing process and door weight to not exceed maximum allowed door energy **E1-05**.

Note: The kinetic energy of the door increases with the square of the speed of their movement. $J = \frac{1}{2} mv^2$

ScdE closing deceleration speed: at this speed the door must securely overcome mechanical resistances during closing. But preferably not too high, so that the gate track is given decrease speed of the ramp **C1-02** after switching speed pressure **ScPS** not long. In the case of changing the resistance due to impurities in the door sill of the door or sudden temperature changes could lead to differences in stopping the of the door in the closed position – incomplete the door or on the contrary impact to the mechanical stop.

Recommendations:

For reliable functioning of the actuator shall happen at this speed and maximum operating temperature rise of the engine to safely overcome the mechanical resistance in so called mouth of the door.

ScPS speed in the closed position. **At this value application should not exceed the current value of the converter in the end position gate 30 to 40%**. Reachable moments of such permissible current values usually do not cause movement the direction of door closed, but are used in conjunction with worm gear ensures the door in the closed position. Higher current values would result in unacceptable warming of the engine increased "transducer" engine noise and damage of the engine or converter. The current value is checked on the keypad. When you enter **ScPS** below the minimum frequency **E1-09** does not pass an internal start signal of the converter and the converter output is switched off even in the presence of the trigger signal S1





PcAc switching point of maximum closing speed **ScLo**. It is set in an area away from potential of mechanical barriers or spacers gates. In case it is not required reductions speed of start when opened. You can set **PcAc** = close to the maximum door size or on the **PoEn**.

PcdE switching point of deceleration speed at closing. Sets with regard to the selected maximum closing speed **ScLo** the deceleration ramp **C1-02** and the value of S-curve **C2-03 and C2-04**, so that the door reached the deceleration speed **ScdE** safely before the end position closed and commuted to the end position by the defined speed. Too high setting has an extension of the closing doors. Then low settings will cause the door will not completely decelerated and they will commute at high speed to the end position closed.

Recommendations: To reduce the mechanical forces in the closing movement of the gate in case of trapping of body parts. It is advisable to set deceleration point to higher values even at the price longer closing time. This is eliminating the effect of higher kinetic energy of the door.

PcEn switch point on pressure speed in the close position. **This point gives practical point stop for gate in the closed position.** Gates execute from the point **PcEn** only track the slowdown of the speed values **ScdE** down the ramp on the **C1-02**. Point **PcEn** must be at least 1-2 cm from the end position closed. In case of setting too low, may not be switch on to pressure speed **ScPS** and flows into the engine high current applications **ScdE**, which is not permissible in terms of warming the engine and and will turn off electronic thermal engine protection in the conveter.

In case that the control IDC signal is changed to go open during closing, the signal on S3 terminal is switched ON for option of using the quick ramp **C1-04** for stopping and the door opens in both operation modes – in basic as well as in extended.

Closing forces

Closing force gate depends on construction of gates, to the parameters U/f curve: ie constants **E1-04 to E1-10**. We recommend change the setting E1-04 = 50 Hz, E1-06 = 50 Hz, E1-07 = 8 Hz.

Then:

E1-05 - the maximum gate voltage determines the strength at high speeds.

E1-08 - the voltage at the center frequency determines the strength gate to the deceleration speed SCDE.

Recommended settings can be found in tab. 5 and 6





7 OVERLOAD EVALUATION

7.1 Evaluation by speed difference

Basic principle of overload evaluation is evaluation of speed reference and real door speed.

In case that the difference of speed reference (analog signal on AM/AC) and real speed (frequency from pulse generator) is higher than value given in **dSoL** for time **tioL** the VJ002v unit generates signal to terminal S4 to immediately block the inverter and signal SGS to lift control system for 300 ms period.

In extended operation mode the door is waiting for 1,5 s and then opens or continues in closing according to control signal status.

Overload evaluation range by speed decrease is set in **PoLA** and **PoLd**.

7.2 Evaluation by current excess

In case that the inverter current set in **L6-02** (% of rated inverter current) is exceeded during closing for time set in **L6-03**, the relay on the terminals MC and MA switches ON. Thus the signal of current overload is given. The door action is analogic to action after evaluation by speed difference, according to selected operation mode.





8 PUSHING IN END POSITIONS

To ensure preservation of end positions CLOSED and OPENED the inverter is given reference SoPS pushing in the open position and ScPS pushing in the close position. In these modes is needed to verify if the input current to motor does not exceed 0,3 – 0,4 A. It could result in inadmissible motor overheating and reducing of its lifetime, eventually in inverter breakdown. Pushing function can be excluded in isPS or by setting of pushing reference, which is lower then **E1-09**.

9 END POSITIONS REGULATION

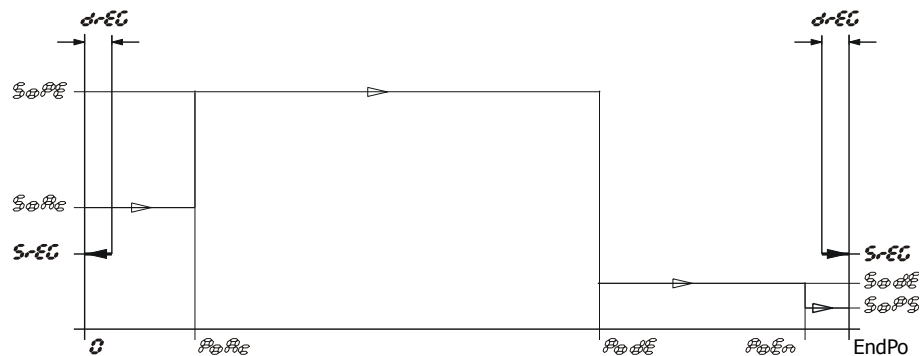

After 3 s after door stopping in end positions the position is read. If this position is changed by mechanical forces impact more than present value of $drEG$ the reference $SrEG$ is sent to inverter and the end position is reinstated.

10 SIGNALS TO DOOR CONTROL SYSTEM

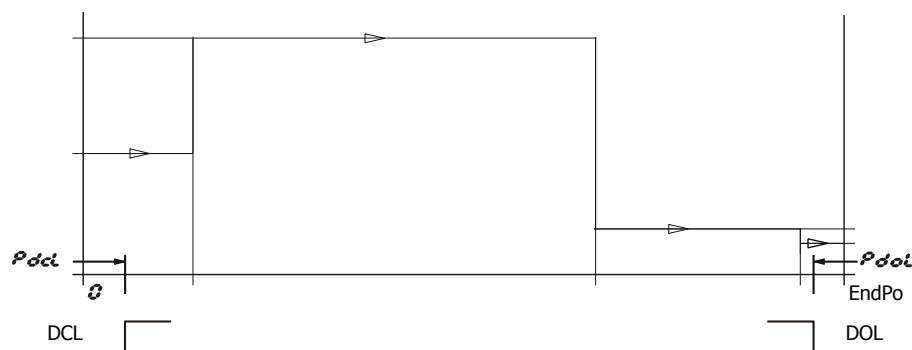

DCL – at interval of positions 0 - $PdCl$ the signal „door closed“ is active - 0V between DCL and D0V

DOL – in the position more than PdL the signal „door opened“ is active - 0V between DOL and D0V

SGS - when overload is evaluated according to Paragraph No. 6 the signal SGS is generated for 300 ms - 24V between SGS and D0V.

The external voltage from lift control system is brought to D24 and to D0V. Signals for lift control system are optically insulated.





Input function VJ002V

Control unit VJ002V of sliding door engine 1RM1 is equipped with 4 programmable digital inputs in1, in2, in3, in4. These inputs can be assigned to the following control functions. It is true that it is not possible to assign a combination of collision, in this case the control locked.

Tab.1 Description of input functions VJ002V

Function No.	Name	Description
0	None	Input is not assigned any function
1	2 x IDC open	Dual input door control. It is necessary to select both functions, otherwise VJ002 reports an error.
2	2 x IDC close	
3	1 x IDC	Single input control 0 = closed 1 = open
4	1 x IDC	Single input control 1 = closed 0 = open
5	Partial opening NO	Opening for the passage of persons, active switch on
6	Partial opening NC	Opening for the passage of persons, active switch off
7 ⁽¹⁾	IOL NO	Signal overload current from the converter active switch on
8 ⁽¹⁾	IOL NC	Signal overload current from the converter active switch off
9	SDC NO	End switch is closed when switch on
10	SDC NC	End switch is closed when switch off
11	SDO NO	End switch is open when switch on
12	SDO NC	End switch is open when switch off
13	SDCd NO	Deceleration end switch for closing switch on
14	SDCd NC	Deceleration end switch for closing switch off
15	SDOd NO	Deceleration end switch for opening switch on
16	SDOd NC	Deceleration end switch for opening switch off
17	LIB NO	Photocell active switch on
18	LIB NC	Photocell active switch off
19	STOP NO	Stop signal active switch on
20	STOP NC	Stop signal active switch off
21	IDC Pulse NO	Pulse control is active on the rising edge
22	IDC Pulse NC	Pulse control is active on falling edge

Note (1): additional evaluation of the possibility of overloading exceeding the set current. However is his position in the search mode, reference and pushed at the end positions, which serves a protective function of the cnnverter and engine.

Rules for selecting functions din1 – din4

1. J002 unit could be operated only in one way signals 1a2, or 3, or 4, or 20, or on 21.
2. Each function can be assigned to maximum of one input (outside function 0) and it is excluded simultaneous use of inverse functions (inverse are 5 / 6, 7 / 8, 9 / 10, 11 / 12, 13 / 14, 15 / 16, 17 / 18, 19 / 20, 21 / 22).





11 IMPORTANT CONTROL AND DSETTINGS INVERTER COMPONENTS AND CONSTANTS

Digital operator

This chapter contains extract from inverter Varispeed J1000 instruction manual and is focused to functions and setting related to 1RM1 drive and to co-operation with VJ002v units. Comprehensive inverter description, including maintenance instructions, faulty diagnosis etc., is available in inverter instruction manual.



	Title	Function
	Data Display Area	Displays the frequency reference, parameter number, etc.
	ESC	Returns to the previous menu.
	RESET	Moves the cursor to the right. Resets the drive to clear a fault situation.
	RUN RUN Light	Starts the drive. Lit while the drive is operating the motor.
	Up Arrow Key	Scrolls up to select parameter numbers, setting values, etc.
	Down Arrow Key	Scrolls down to select parameter numbers, setting values, etc.
	STOP	Stops the drive. Note: Stop priority circuit. A fast-stop is available by pressing the STOP key when the drive detects a danger even if the drive is running by a signal from the multifunction contact input terminal (REMOTE is set). To avoid stoppage by using the STOP key, set o2-02 (STOP Key Function Selection) to 0 (Disabled).
	ENTER	Selects all modes, parameters, settings, etc. Selects a menu item to move from one display screen to the next.
	LO/RE Selection Key LO/RE Light	Switches drive control between the operator (LOCAL) and the control circuit terminals (REMOTE). Note: LOCAL/REMOTE key effective during stop in drive mode. Lit while the operator (LOCAL) is selected to run the drive.
	ALM LED Light	Flashing: When an alarm occurs, oPE detected Lit: When the drive detects an alarm or error
	REV LED Light	On: Motor is rotating in reverse Off: Motor is rotating forward
	DRV LED Light	On: Drive Mode Off: Programming Mode
	FOUT LED Light	On: Displays output frequency (Hz)

Tab 2. Digital operator J1000





Structure of converter control J1000

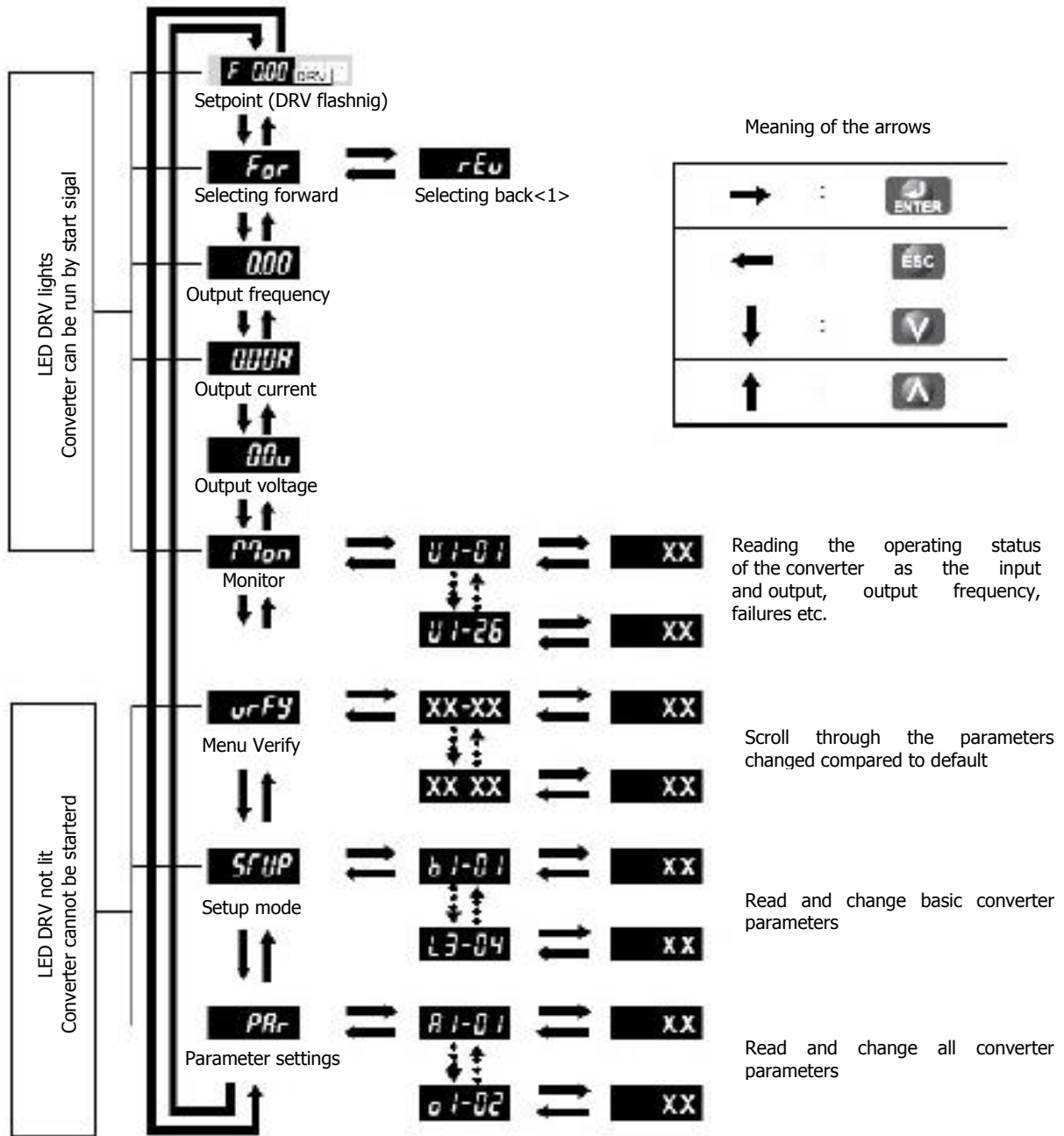

LED lit after selecting LO mode





11.1 V/f pattern

Correct setting of V/f pattern is very important for correct door function.

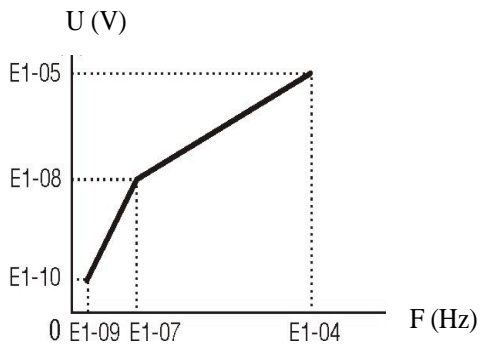

Typical setting for 3,0 m door:

setting is possible only when the inverter is turned OFF and without signals S1 and S2

E1-04 = 50 Hz

E1-05 = 145 – 165 V

E1-06 = 50 Hz

E1-07 = 8 Hz

E1-08 = 60 – 66 V

E1-09 = 2,0 Hz

E1-10 = 24 V

E1-04 maximum output frequency (for analog signal 10V)

E1-05 maximum voltage

- determine motor torque and opening and closing door forces
- too high setting can cause unacceptably high closing forces
- too low setting can cause undesirable evaluations of over-torque and changeover during closing

E1-06 base frequency - in this application should be set **E1-06 = E1-04**

E1-07 middle output frequency

E1-08 middle output frequency voltage

- optimal motor torque at low speeds should be set

E1-09 minimal output frequency

E1-10 minimal output voltage frequency

- pushing power in utmost positions should be set
- starting frequency after inverter start
- by giving the reference, which is lower than present value in **E1-09** start does not run though the starting signal is ON





11.2 Ramps and S-curve pattern

At step change of frequency reference the output frequency change is flowing according to setting constants **C1-01** and **C1-02**. Next two ramps **C1-03** and **C1-04** are using for quick stop after change of the command from closing to opening or from opening to closing (only in extended control mode).

S - curve **C2-01 – C2-04** furthermore makes the process of output frequency change smoother after the inverter start.

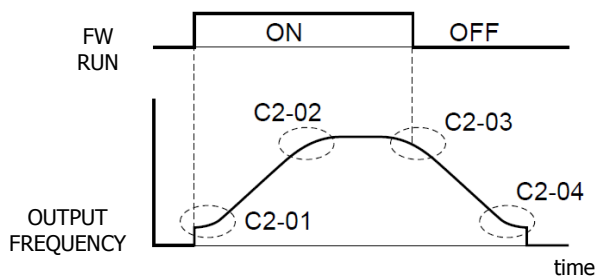

11.3 Programmable inputs S3, S4

H1-03: S3 = 7 ramps changeover

H1-04: S4 = 8 base block

At the moment of over-torque evaluation the base block signal is activated on terminal S4. This makes possible to achieve the shortest doorstop.

Signal on terminal S3 activate next two ramps for quick stopping during door running when the direction command is changed.

11.4 Over-torque detection

If an excessive load is applied to the motor, output current increases and the inverter indicates the door blocking. Over-torque detection level is set in **L6-02**, over-torque detection time in **L6-03**. Too low setting of **L6-03** causes undesirable over-torque evaluation in door starting up modes.

11.5 Overload detection - IOL

Converter is equipped with an electronic thermal motor protection - converter parameters **E2-01, L1-01, L1-2**.

E2-01 - nominal motor current

L1-01 - thermal protection characteristics - settings1 increases the sensitivity of protection for low output frequency when it is own engine cooling has less efficacy

L1-02 - time constant of protection

Recommended settings E2-01 = 1.0A, L1-01 = 1 (self-cooling), L1-02 = 4.0min.

This setting ensures switching off the converter - report oL1. When gate do not go to the limit position (engine switches to pressured) and engine consumes power above 0.7 A at frequencies below 10 Hz. Time of switched off by current values 1-5 minutes. Short-crossing value of 1 A during operation the gate or pressured currents up to 0.4 A will not cause undesired triggering.





11.6 Fault Diagnoses

The inverter is equipped by extensive diagnostics of the faults. Comprehensive list of faults is in inverter instruction manual.

Faults that can be diagnosed in 1RM1 drive and corrective actions:

Tab 3. Alarm and Error Displays

LED Operator Display	Fault Name	Possible Solution
oL3	Overtorque Detection 1	Inverter output current exceeded the present value in constant L6-02 , standard operating report at over-torque.
bb	External base block	Base block command at multi-function terminal is active, standard operating status at evaluation of overload.
CrST	STOP by pressing STOP/RESET button during running by the control circuit terminals	Reset by pressing RESET button in case of absence of signal START on terminals or turn the inverter OFF.
oC	Overcurrent	Short-circuit at the inverter output, motor short-circuit or short-circuit of motor wiring. Check the motor and motor wiring.
GF	Ground fault	Ground fault on the inverter output, motor short-circuit or short-circuit of motor wiring.
ou	Main circuit overvoltage	Overvoltage in power supply. Overvoltage in DC bus because of excessive deceleration of big inertial masses.
Uu 1	Main circuit low voltage	Low voltage in power supply, loose terminals in inverter power supply part.
oH	Cooling fin overheat	Overheat because of high air temperature or inverter overload operation.
oL1	Motor overload	Reaction of motor overload protection in inverter that operates by electronic overload relay. Wrong setting of overload protection value, inadmissible motor load.
oL2	Inverter overload	Reaction of inverter overload protection operates by electronic overload relay. Wrong setting of overload protection value, inverter overload operation.
CAL	Communication error over the line	Incorrect programming b1-01 and b1-02
EF	Run Command Input Error	Replace the VJ002V
CE	Communication error on the serial line	Incorrect programming b1-01 and b1-02
EF1 - EF5	External Fault (input terminal S1 to S5)	External fault at multi-function input terminal S1 – S5.
CPF01 - CPF24	Hardware is damaged.	Replace the drive.





12 SET 1RM1

Motor	SKg 63-6B, 120W 3 x 230 / 400 V, D / Y 0,9 / 0,6 A, D / Y Two-phase pulse generator, 16 ppr.
Gearbox	SRT28 i=7 HE
Frequency inverter	JZAB 0P2 BAA
Noise filter	3G3JV PFI 1010 or A1000 – FIV1010
Door control unit	VJ002V

Tab. 4 Technical Data 1RM1

Power Supply	Power	1 x 230 V +10% -15%
	Power consumption - maximum - typical for 3,0m door	0,6 kVA 0,25 kVA
Gearbox Output 7:1	Speed and torque	125 min ⁻¹ / 7,5 N.m 250 min ⁻¹ / 3,2 N.m
	Maximum sliding length	71 revolutions
	Radial load	max. 400 N / 72 mm from center of gearbox
Pulley d=50mm	Max. speed / pull	0,35 ms ⁻¹ / 300 N 0,45 ms ⁻¹ / 235 N 0,60 ms ⁻¹ / 175 N
	Typical speed / pull for 3,0m door	0,25 ms ⁻¹ / 300 N
	Max. sliding length PG resolution Opening force	10,0 m 0,29 mm 0 - 300 N
	Protection - geared motor - electronic	IP 55 IP 20
Working area and Environmental Conditions	Working area	- indoor
	Ambient temperature	-10 to +35 °C
	Storage temperature	-20 to +35 °C
	Elevation	1500 m or less
	Humidity	max. 90% RH (non-condensing)
Expected Lifetime		10 000 000 cycles





Mechanical dimensions:

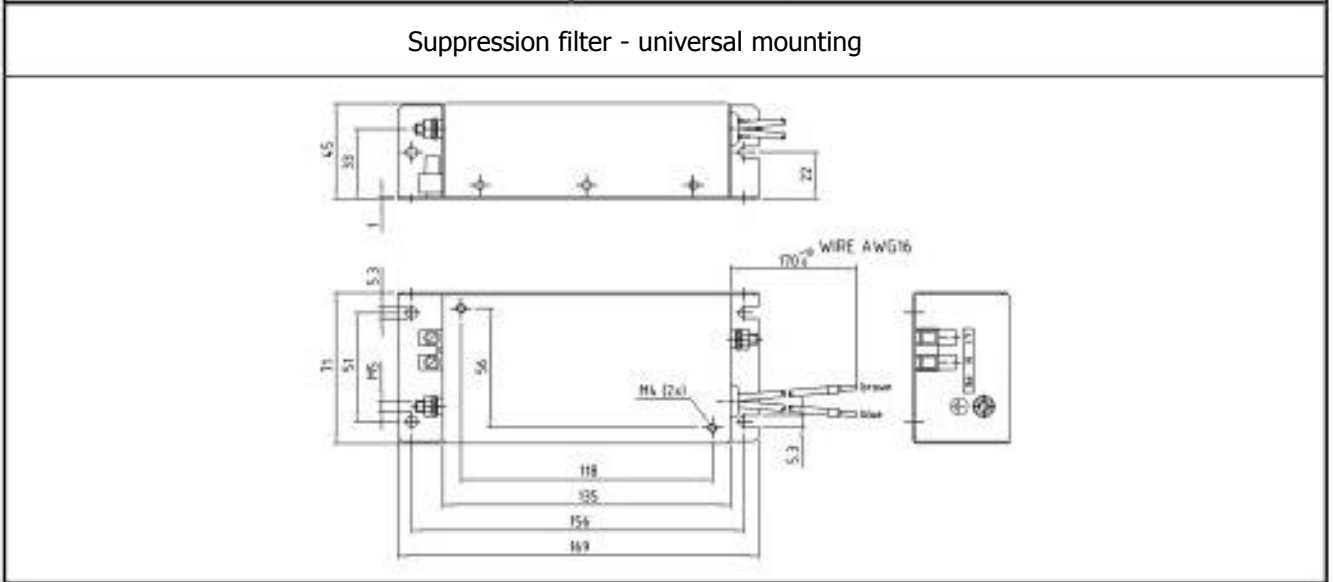
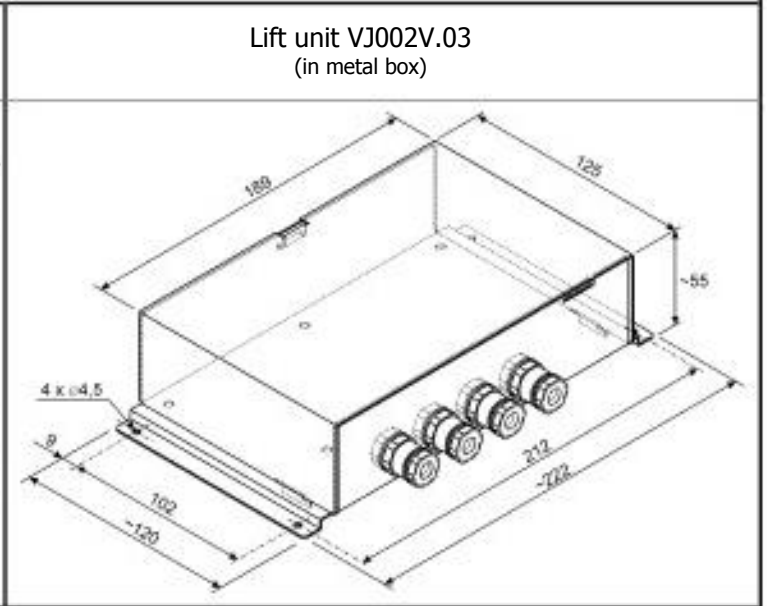
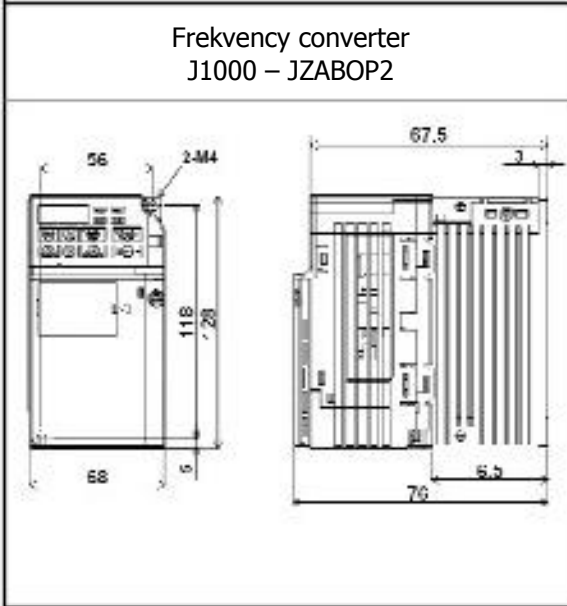
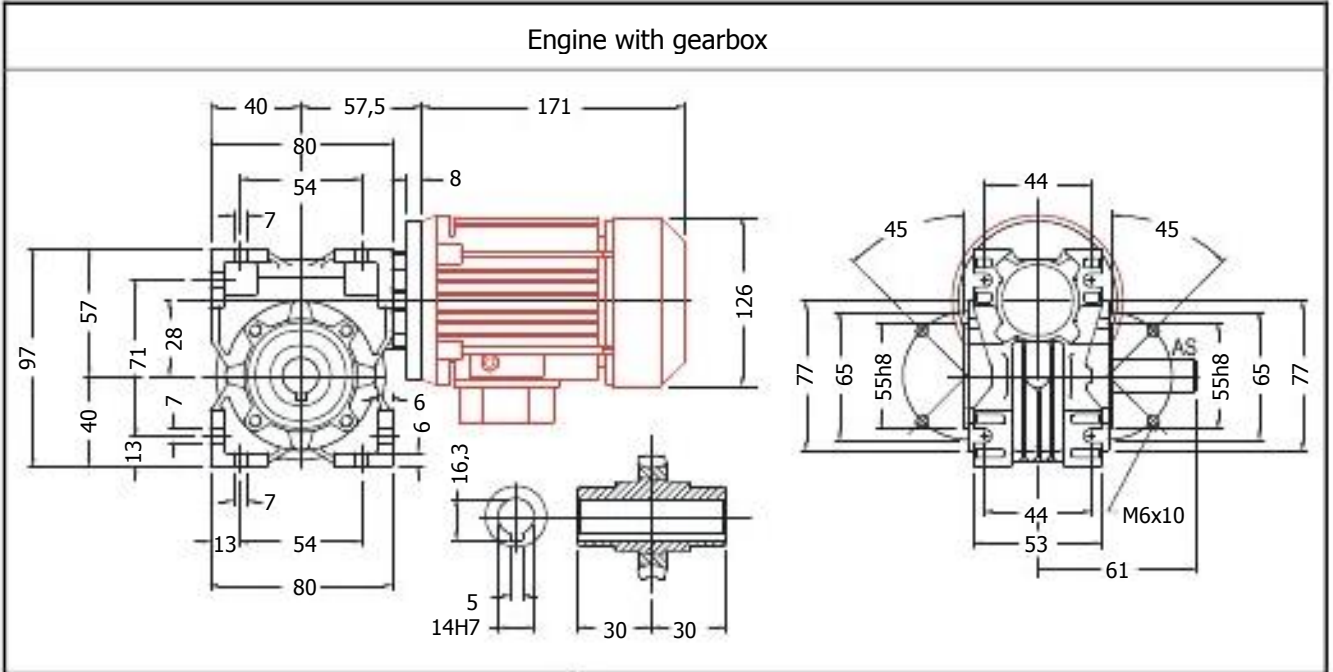

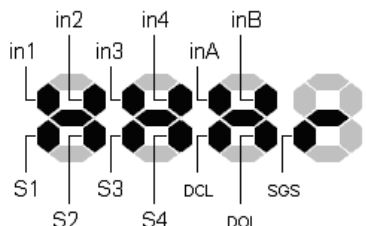

Tab. 5 Setting Parameters VJ002V

	Display indication 0 = nothing displayed 1 = momentary position [pnd] 2 = analog output from inverter [%] 3 = real motor speed [%] 4 = frequency reference for inverter [%] 5 = last detected errors 6 = input/output monitor 7 = speed difference 	Setting Range: 0-7	Unit	Typical setting
PoAc	Opening acceleration point	0-8000	pnd	15
PodE	Opening deceleration point	0-8000	pnd	PoEn-290
PoEn	Opening end point	0-8000	pnd	PoEn
PdoL	Minimum for DOL (Door Open Limit)	0-8000	pnd	PoEn-360
PoLA	Upper point of overload evaluation range	0-8000	pnd	36
PcAc	Closing acceleration point	0-8000	pnd	PoEn-73
PcdE	Closing deceleration point	0-8000	pnd	306
PcEn	Closing end point	0-8000	pnd	10
PcdL	Maximum for DCL (Door Close Limit)	0-8000	pnd	12
PoLd	Lower point of overload evaluation range	0-8000	pnd	95
PPAo	Partial opening end point	0-8000	pnd	437
SoPE	Opening speed	5-100	%	70
SodE	Opening deceleration speed	5-100	%	20
SoPS	Opening pushing speed	5-100	%	10
ScLo	Closing speed	5-100	%	70
ScdE	Closing deceleration speed	5-100	%	20
ScPS	Closing pushing speed	5-100	%	10
SreF	Speed for reference searching	5-100	%	25
SrEG	Speed for end position regulation	5-100	%	25
DrEG	Deviation of end position regulation	5-100	pnd	10
DsoL	Speed difference for overload evaluation	10-80	%	60
tiOL	Time for overload evaluation	0.1-25.5	s	0.5
tSPV	$tSPV = 75\ 000\ 000 / \text{speed} / \text{marks} / F_{max}$ speed – motor rated speed at 50 Hz marks – PG division Fmax – max. inverter output frequency E1-04	25 – 150	ms	98
tPAo	Time for waiting to PPAo	0.1-25.5	s	2.0
iSPS	OFF/ON pushing in the end position	0-1	-	0
ctol	Overload detection 0 = No function 1 = Opening overload detection 2 = Closing overload detection 3 = Opening/Closing overload detection	0 – 3	-	3
ctrf	LIB and STOP for reference searching 0 = LIB and STOP ignored 1 = LIB and STOP detection	0 – 1	-	1
Nref	směr referencování 0 = reference to close 1 = reference to open 2 = IDC reference setting	0 – 2	-	0





Transmission pnd on display VJ002V to mm:
(Pulley d=50mm, gearbox i=7)

728pnd ≈ 1000mm

<i>din1</i> <i>din2</i> <i>din3</i> <i>din4</i>	0 – no function	11 – Limit switch closed SDC (NO)
	1 – 2 x IDC basic mode, open	12 – Limit switch closed SDC (NC)
	2 – 2 x IDC basic mode, close	13 – Limit switch opened SDO (NO)
	3 – 2 x IDC extended mode, open	14 – Limit switch opened SDO (NC)
	4 – 2 x IDC extended mode, close	15 – LIB NO – (NO, active if 1)
	5 – 1 x IDC basic 0 – close, 1 – open	16 – LIB NC – (NC, active if 0)
	6 – 1 x IDC basic 1 – close, 0 – open	17 – STOP NO – (NO, active if 1)
	7 – 1 x IDC extended, 0 – close 1 – open	18 – STOP NC – (NC, active if 0)
	8 – 1 x IDC extended, 1 – close 0 – open	
	9 – IOL overload signal (NO, active if 1)	
	10 – IOL overload signal (NC, active if 0)	
Typical settings: din1=5, din2=3, din3=17, din4=19		
<i>VerS</i>	SW version	- - - -
<i>Lerr</i>	Last 4 detected errors	- - - -
	0 = no function	
	1 = error in definition of inputs function	
	2 = overload during reference searching	
	3 = overload in the end position, signal from inverter	
	4 = overload during closing, signal from inverter	
	5 = overload during closing, speed difference	
	6 = limit switch SDO switched ON before switching OFF of limit switch SDC	
	7 = pulse generator error	
8 = opening door blocked (>10s)		
<i>Fact</i>	Parameters set reading up into memory	11-16
	11 = Parameters set No. 1	14 = Parameters set No. 4
	12 = Parameters set No. 2	15 = Parameters set No. 5
	13 = Parameters set No. 3	16 = Parameters set No. 6
	0: no function	
<i>Hand</i>	1: testing function, button UP – OPENING, button DOWN – CLOSING	





Tab. 6 - Inverter Setting for operation with VJ002V - (Constants List)

Const. No.	Name	Setting Range	Initial Setting for 1RM1	Necessary /typically
b2-04	DC Injection Braking Time at Stop	0.00 – 10.0	0	0
C1-01	Acceleration time 1	0.0 – 999	1.5	0.5 – 1.5
C1-02	Deceleration time 1	0.0 – 999	1.5	0.5 – 1.5
C1-03	Acceleration time 2	0.0 – 999	1.0	0.1 – 1.5
C1-04	Deceleration time 2	0.0 – 999	0.2	0.1 – 0.5
C2-01	S – curve	0.00 – 10.00	1.0	1.0 – 1.5
C2-02	S – curve	0.00 – 10.00	1.0	0.6 – 1.5
C2-03	S – curve	0.00 – 10.00	1.0	0.6 – 1.5
C2-04	S – curve	0.00 – 10.00	1.0	0.8 – 1.5
E1-01	Input power voltage	155 – 255	230	200 – 230
E1-03	V/f pattern	0 – FF	FF	FF
E1-05	Maximum voltage	0.1 – 255.0	145	145 – 165
E1-07	Middle output frequency	0,1 – 399	8.0	8.0
E1-08	Middle output frequency voltage	0.1 – 255	66	60 – 66
E1-09	Minimum output frequency	0.1 – 10.0	2.0	2.0
E1-10	Minimum output frequency voltage	0.1 – 50	24	18 – 24
E2-01	Motor rated current	0 – 1,9 A	1.0	0.8 – 1.0
E2-02	Motor Rated Slip	0.00 – 20.00	3.0	1.8 – 3.2
E2-03	Motor No-Load Current	0 – E2-01	0.8	0.5 – 0.8
E2-05	Motor Line-to-Line Resistance	0.00 – 65.00	40.0	40 – 55
H1-03	Multi-function input selection 3	0 – 67	7	7
H1-04	Multi-function input selection 4	0 – 67	8	8
H2-01	Multi-function output selection	0 – 13D	0	chod
H3-03	Terminal A1 Gain Setting	-999 – 999 %	115.5	115.5
L1-01	Motor Overload Protection Selection	0 – 2	1	1
L1-02	Motor Overload Protection Time	0.1 – 5 min	4	1 – 4
L2-01	Momentary Power Loss Operation Selection	0 – 2	2	2
L6-01	Torque Detection Selection 1	0 – 4	2	2
L6-02	Torque Detection Level 1	0 – 300	150	120 – 160
L6-03	Torque Detection Time 1	0.0 – 10.0	0.5	0.5 – 1.0

Settings in bold are required as absolutely necessary to comply to ensure cooperation VJ002V and converter.

The other converter parameters are not listed in the table, it is necessary to leave in the factory presets. The change could result in malfunction of the 1RM1.

In case it is not clear, if it is neither any undesired transcription constants in Tab. No.3 not listed, it is possible to perform check in the verify menu, where the parameters are changed from the default.





13 PROGRAMMABLE RELAY ZEN

The switchboard 1RM1 for gate drive is equipped with programmable relay ZEN 20C1DR-D-V2, which processes the signals to / from the control unit gate VJ002V.

Programmable display relays can read information about the status of inputs and outputs. If the relay is running and ongoing internal processing of the program is on programmable display relay legible inscription RUN

Information from the programmable display relay ZEN

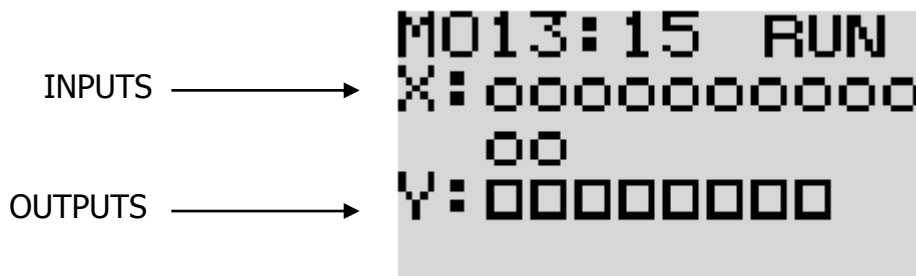

Wheels at the top of the screen are referred inputs to the programmable relay, where each wheel is a single input. Wheels indicating on the first line from left to inputs I0, I1, I2, I3, I4, I5, I6, I7, I8, I9 and the second line inputs from left Ia, Ib. If the wheel is blank viz. image, then the input is not active (it is not energized). If the wheel is whole colored (all black) is applied voltage on the input is active.

Squares at the bottom of the screen are referred outputs to the programmable relay, where each square is a single output. Squares are in one row and from the left signal outputs Q0, Q1, Q2, Q3, Q4, Q5, Q6, Q7. If check box is empty viz. image, then output is not active (not closed output contact). If the square is whole colored (all black) output is active, output contact is closed.





Inputs / Outputs information:

I/O	Indicator	Function	Initial Setting for 1RM1
I0	Black	POWER ON - 230V AC.	Black
	Black/White	POWER OFF.	
I1	Black	Button STOP is not pressed.	Black
	Black/White	Button STOP is pressed.	
I2	Black	Button OPEN is pressed.	Black/White
	Black/White	Button OPEN is not pressed.	
I3	Black	Button CLOSE is pressed.	Black/White
	Black/White	Button CLOSE is not pressed.	
I4	Black	Button STEP-BY-STEP is pressed.	Black/White
	Black/White	Button STEP-BY-STEP is not pressed.	
I5	Black	Button OPEN/automaticallyCLOSE is pressed.	Black/White
	Black/White	Button OPEN/automaticallyCLOSE is not pressed.	
I6	Black	Fire detector	Black
	Black/White	Fire detector – alarm – door closing.	
I7	Black	LIB – all OK.	Black
	Black/White	LIB - alarm.	
I8	Black	Door moving.	Black/White
	Black/White	Door not moving.	
I9	Black	Overload on.	Black/White
	Black/White	Overload off.	
Ia	Black	Door partial open.	Random
	Black/White	Door close limit.	
Ib	Black	Door partial close.	Random
	Black/White	Door open limit.	
Q0	Black	UPS on.	Black
	Black/White	UPS off.	
Q1	Black	Flash on.	Black/White
	Black/White	Flash off.	
Q2	Black	Door close limit.	Random
	Black/White	Door partial close.	
Q3	Black	Door open limit.	Random
	Black/White	Door partial open.	
Q4	Black	Door partial open.	Black/White
	Black/White	CLOSE.	
Q5	Black	OPEN.	Random
	Black/White	CLOSE.	
Q6	Black	LIB – alarm.	Black/White
	Black/White	LIB – all OK.	
Q7	Black	Button STOP is pressed.	Black/White
	Black/White	Button STOP is not pressed.	





14 PERIODICAL INSPECTIONS

14.1 Inverter

Part	Inspection	Corrective procedure
Terminals, mounting screws, connectors , etc.	Loose screws and connectors, cables conditions	Tighten loose screws, correct cables connections
Cooling fins	Dirty or dusty fins	Clean off any dirt and dust with dry compressed air at pressure 0,4-0,5 MPa
PCB	Conductive dirt or oil mist	Clean off any dirt and dust with dry compressed air at pressure 0,4-0,5 MPa
Cooling fan	Abnormal noise or vibration	Replace the cooling fan
Power components and smoothing capacitor	Abnormal color or discoloration	Replace, contact your supplier

Part replacement guidelines

Part	Standard replacement period	Replacement method
Cooling fan	3 to 5 years	Replace with new part
Smoothing capacitor	5 to 10 years	Replace with new part
Contactors and relays	-	Determine need by inspection
Fuses	10 years	Replace with new part

14.2 Cabinet

Part	Inspection	Corrective procedure	Interval
Terminal block	Loose screws Loose connectors	Tighten loose screws Reconnect loose connectors	1 year
Contactors, relays	Loose connections Visual check	Tighten loose connections Replace (determine need by inspections)	1 year
Residual current device	Fitting freewheels protector TEST by button on protectors	Press TEST button	1 month

14.3 UPS – required user maintenance

Part	Inspection	Replacement method	Interval
Battery	If gate closed of full opening during power failure of switchboard 1RM1. Battery life is only one year.	Replace with new part!	1 year





15 CIRCUMFERENTIAL SCHEMATICS

15.1 Power supply

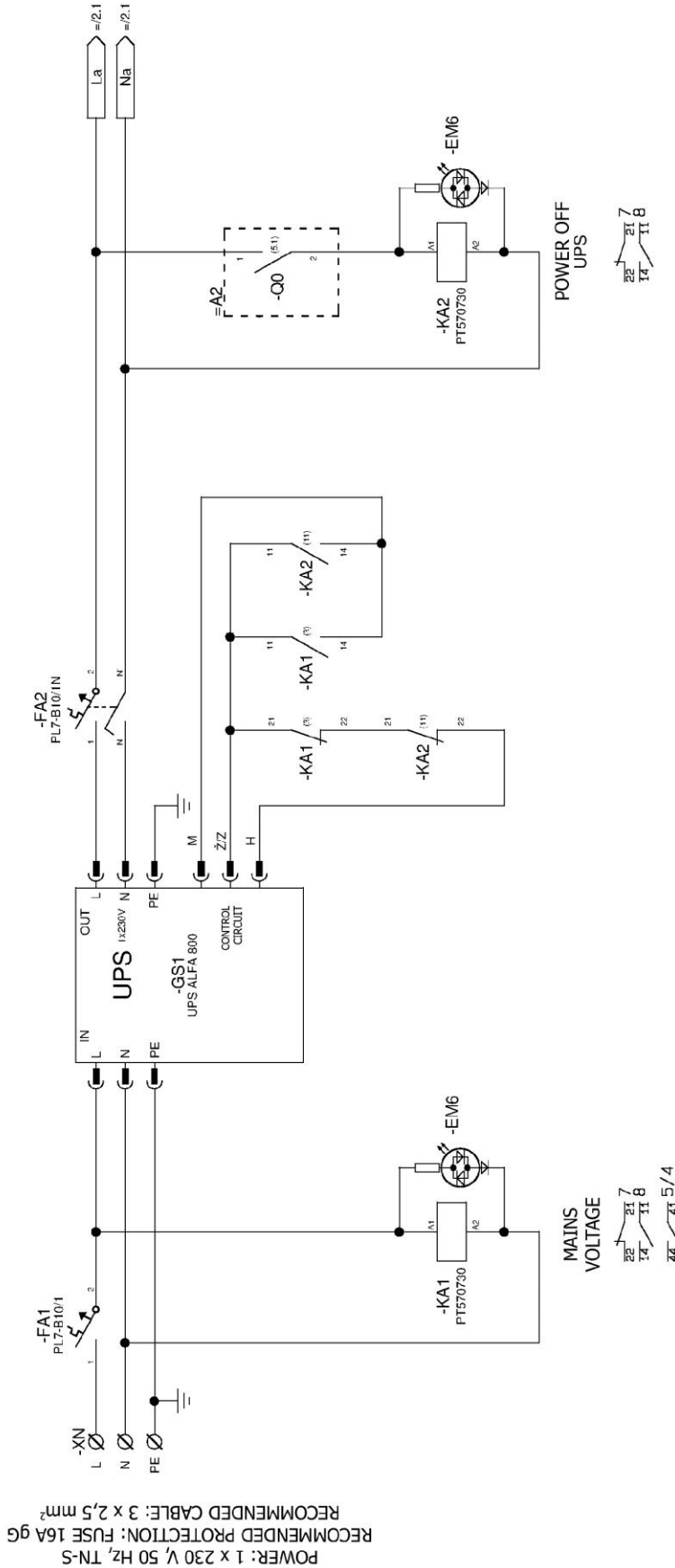

RECOMMENDED BATTERY TIME IS ONE YEAR. REPLACED BATTERY AFTER ONE YEAR.





15.2 Power unit

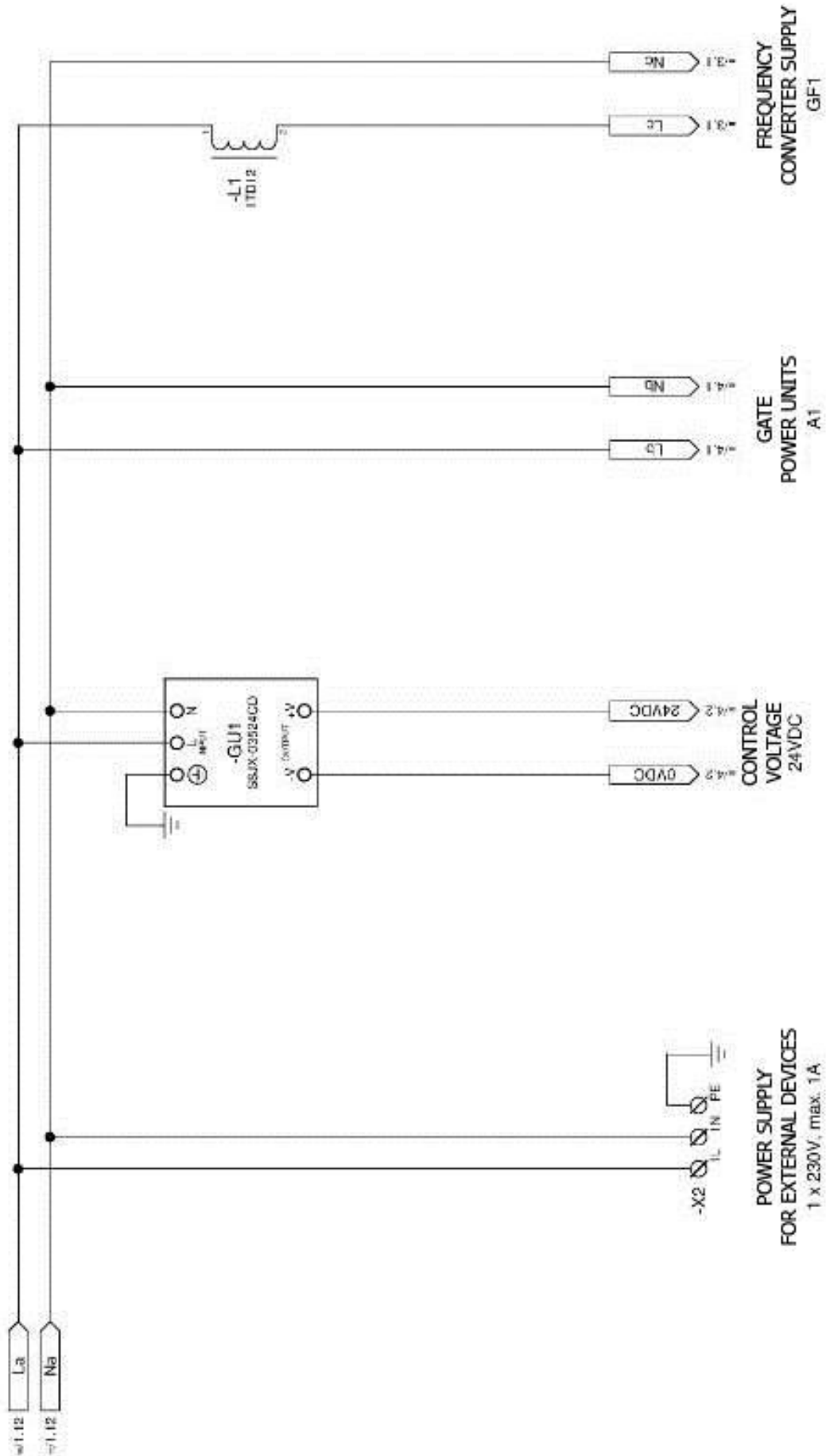



15.3 Frequency converter circuit

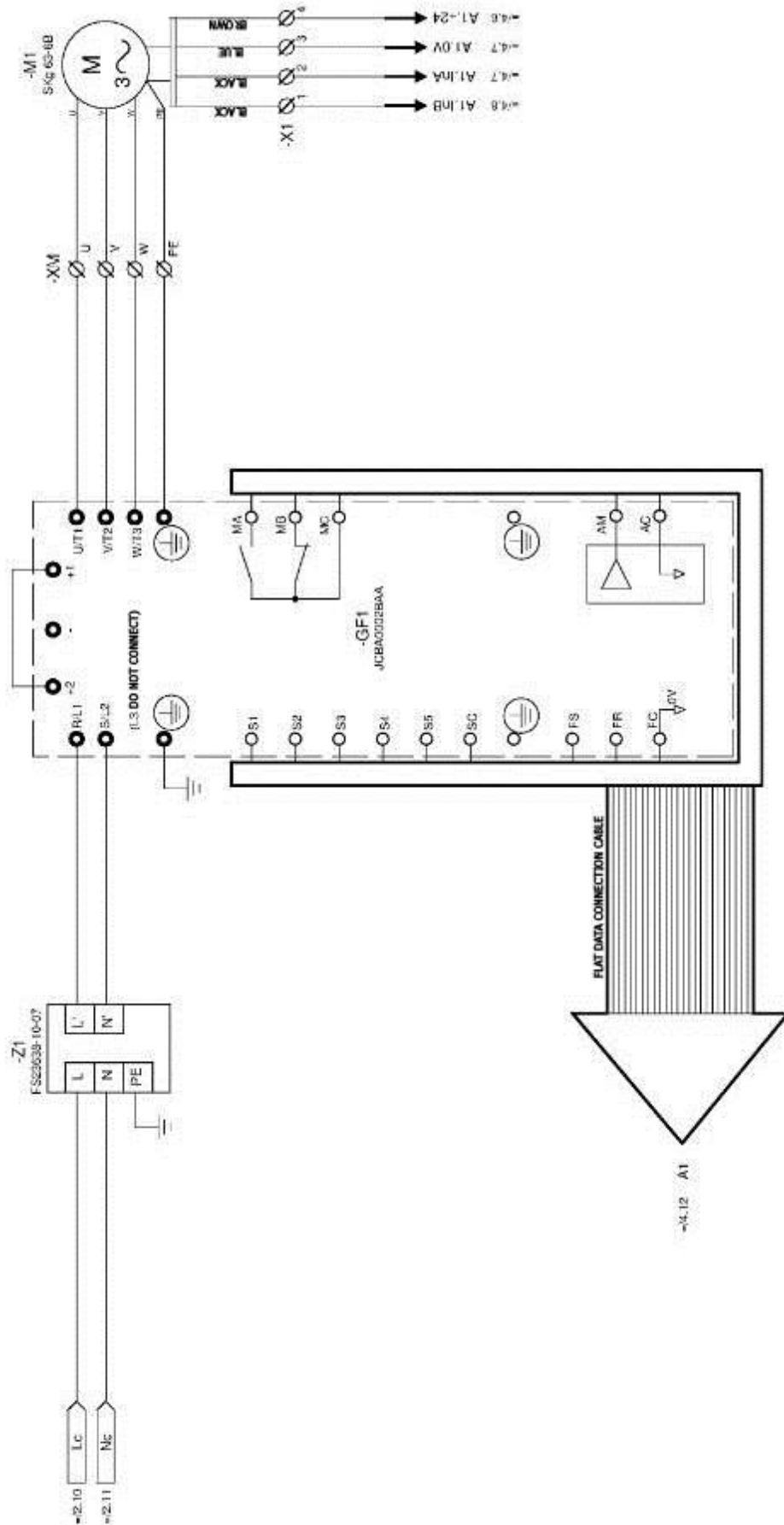



15.4 Door unit

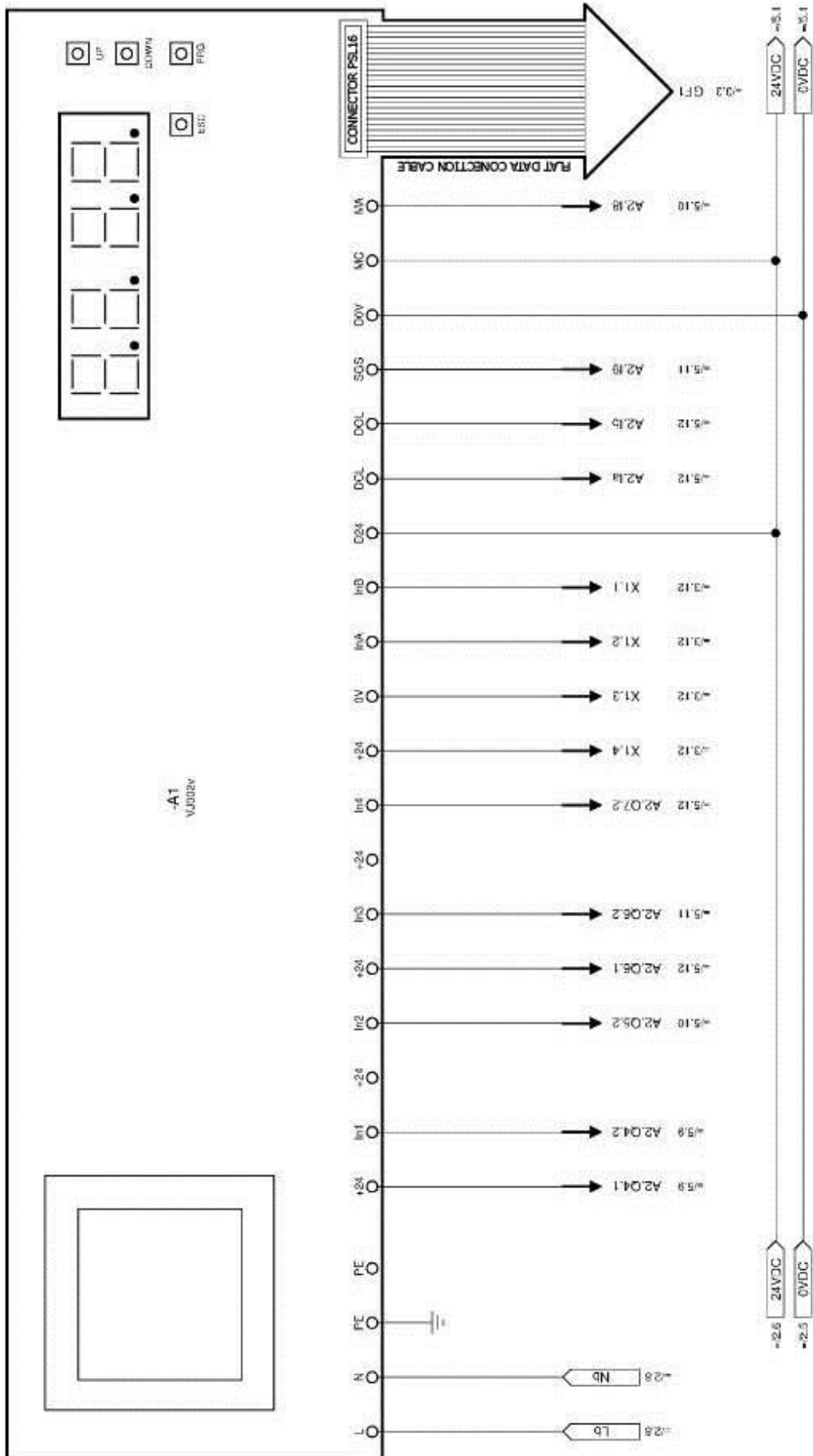



15.6 Controls

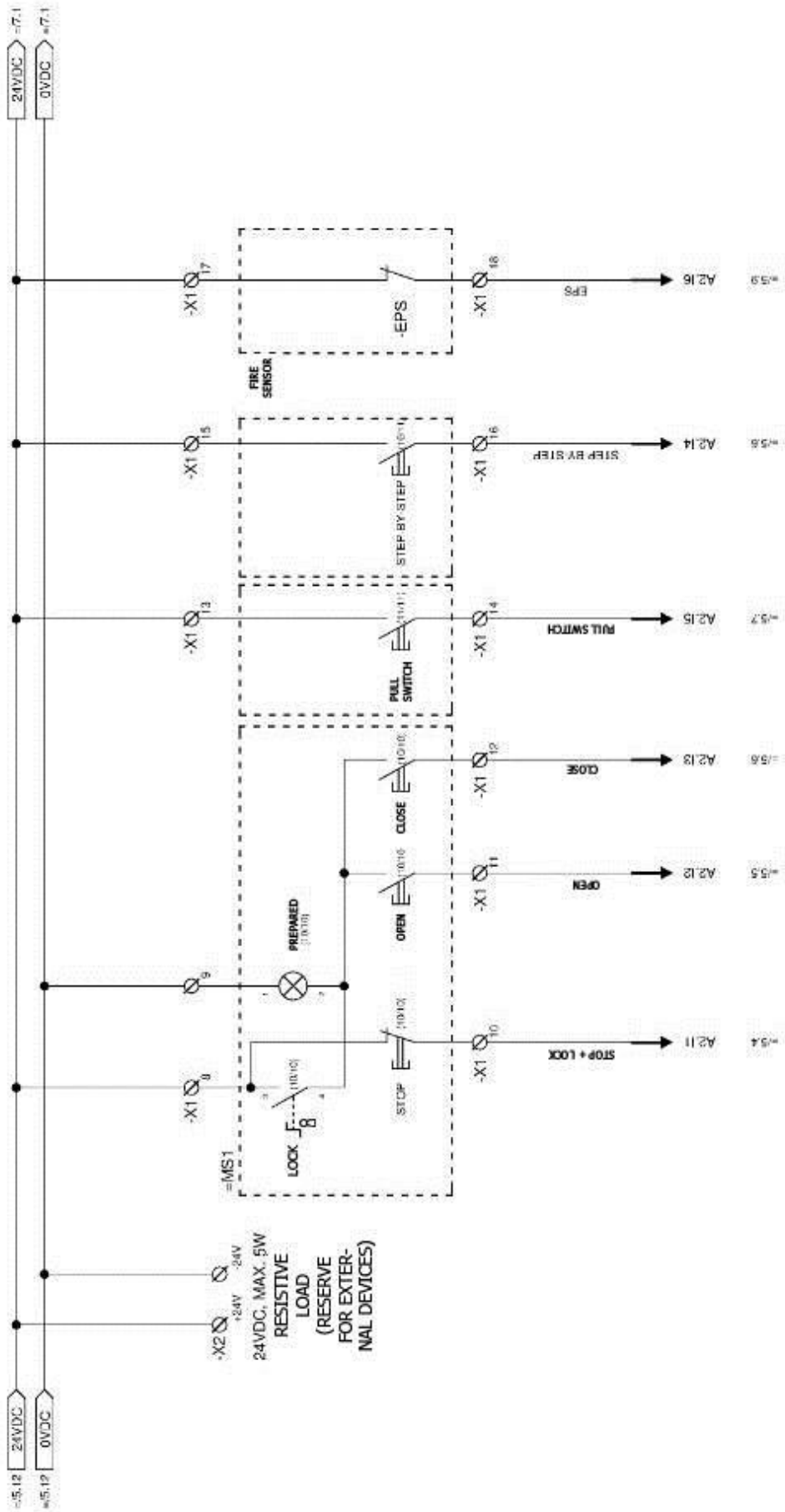



15.7 Photocell, flashlight (signalization)

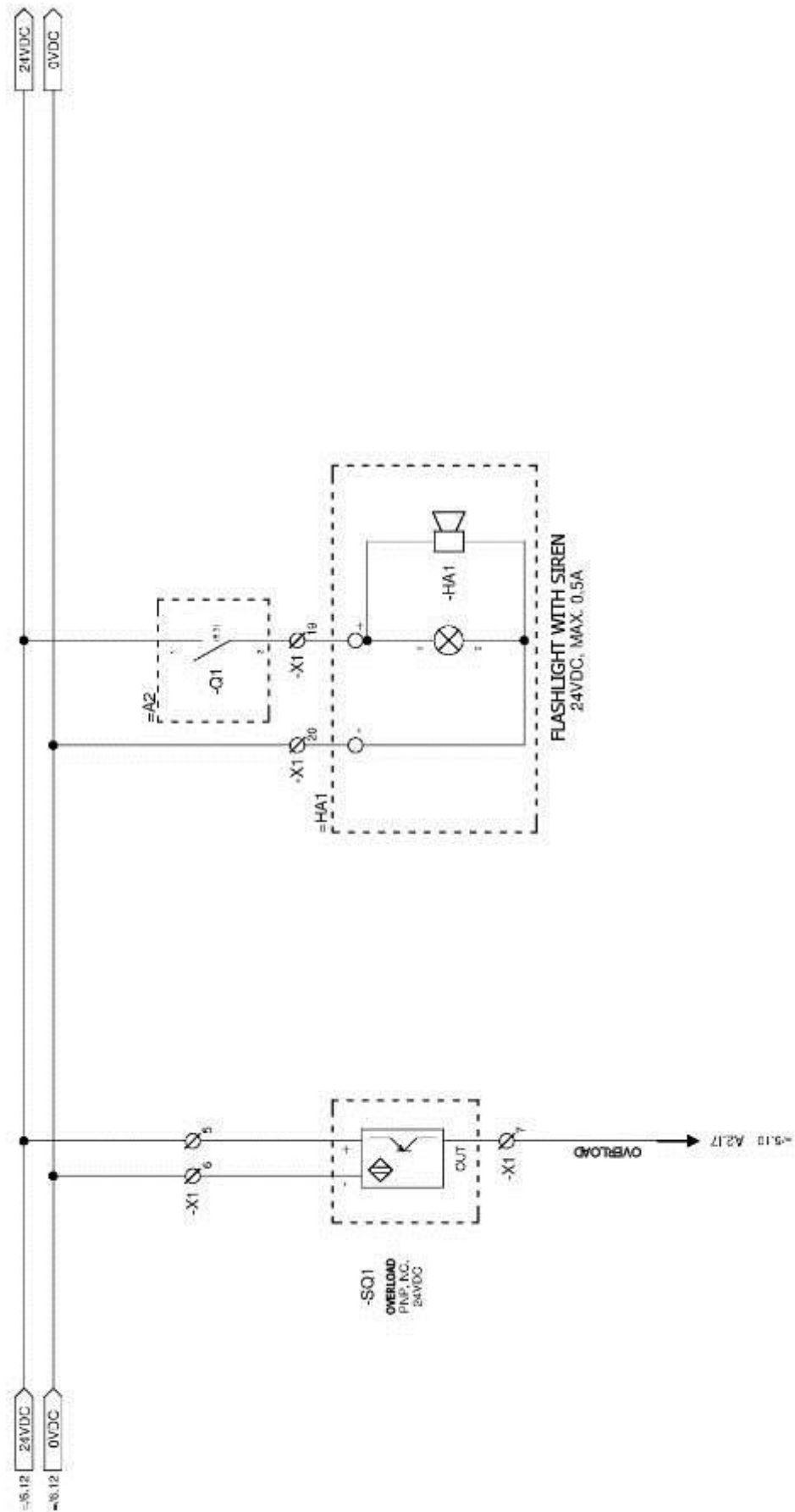



15.8 Signalization of door status

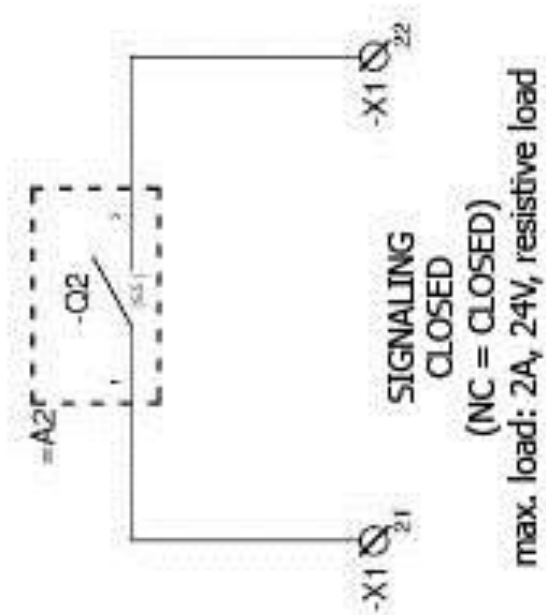
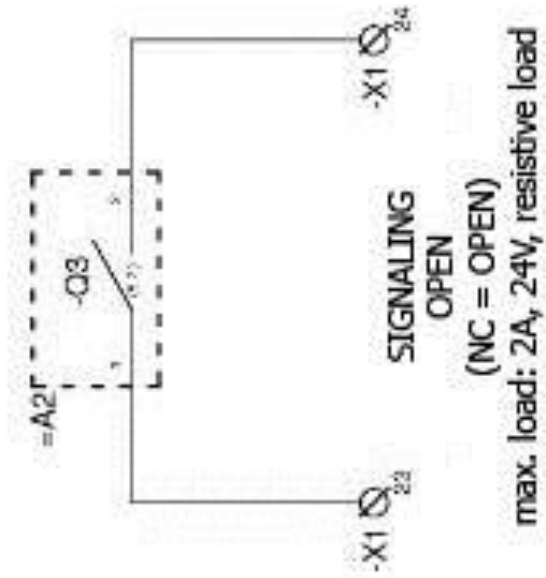



15.9 Cabling 1

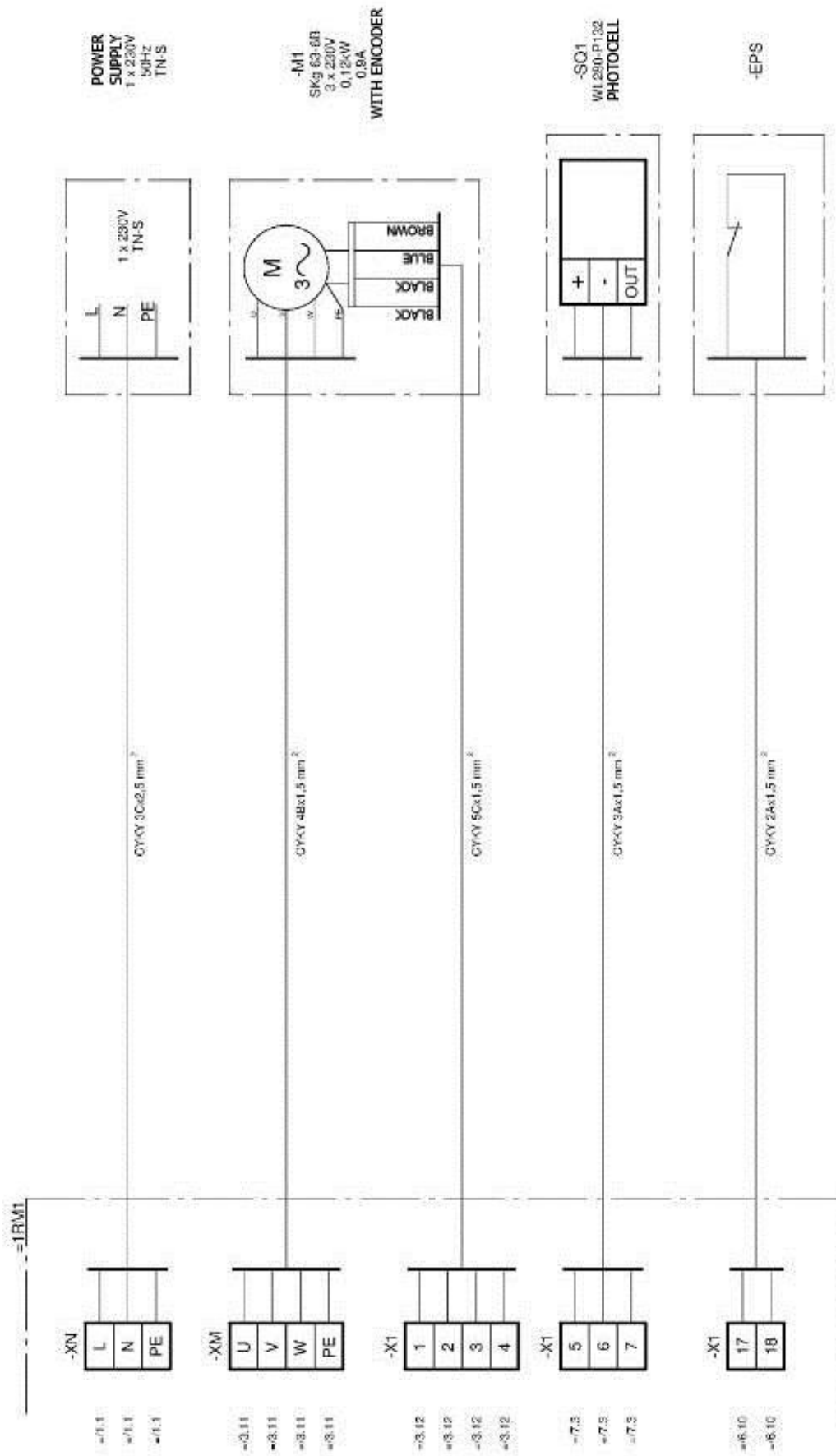



15.10 Cabling 2

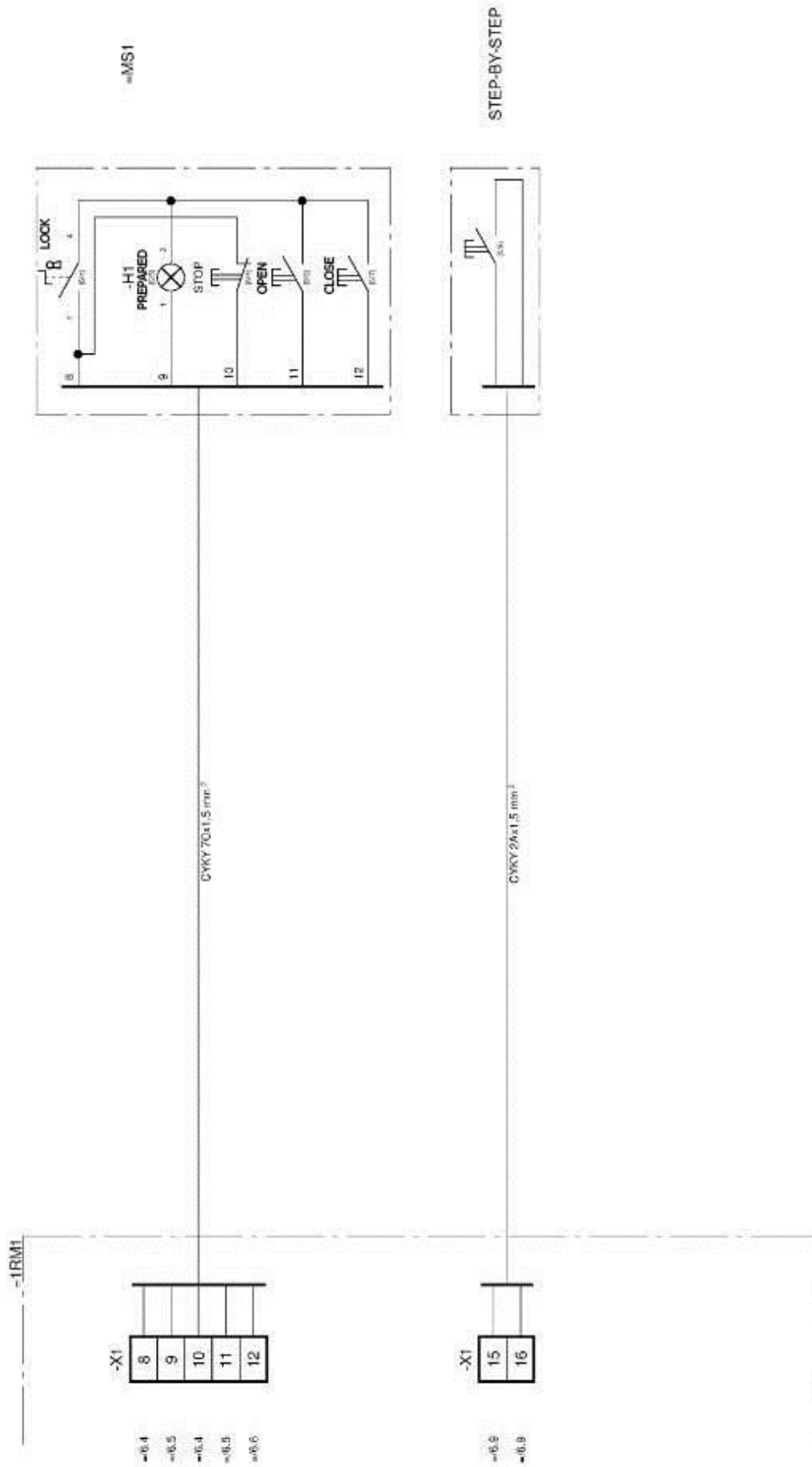



15.11 Cabling 3

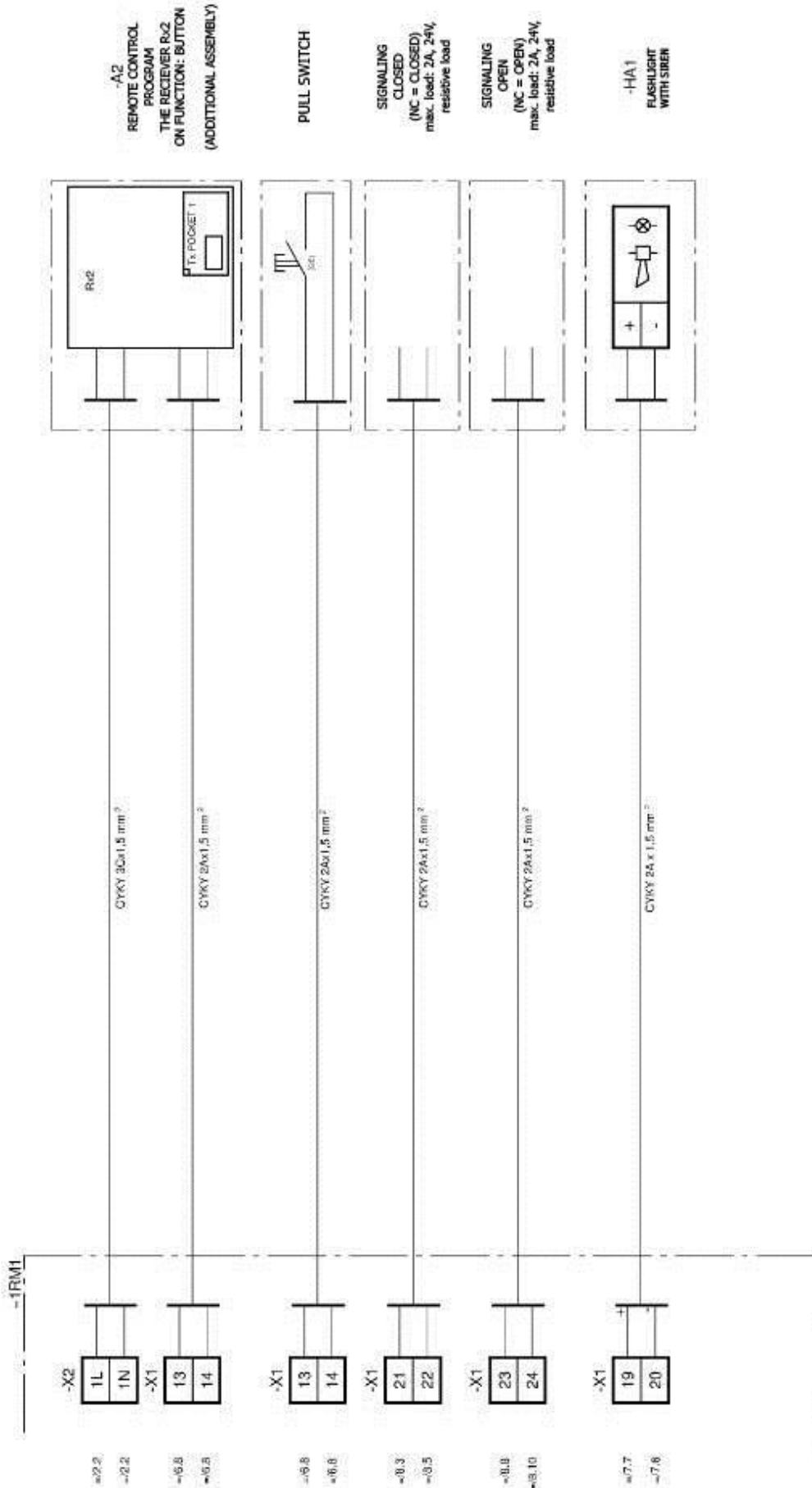

-A2
 REMOTE CONTROL
 PROGRAM
 THE RECEIVER Rv2
 ON FUNCTION: BUTTON
 (ADDITIONAL ASSEMBLY)

PULL SWITCH

**SIGNALING
 CLOSED
 (NC = CLOSED)**
 max. load: 2A, 24V,
 resistive load

**SIGNALING
 OPEN
 (NC = OPEN)**
 max. load: 2A, 24V,
 resistive load

**-HA1
 FLASHLIGHT
 WITH SIREN**





15.12 Sensor connection for the drive 1RM1

In case of requirement connection of fire detectors to the rack 1RM1 is necessary to order module for controlling detectors - "module Cemtro Tlachlas" which includes entry for a balanced loop of sensors. It is necessary to connect according to the attached schedule.

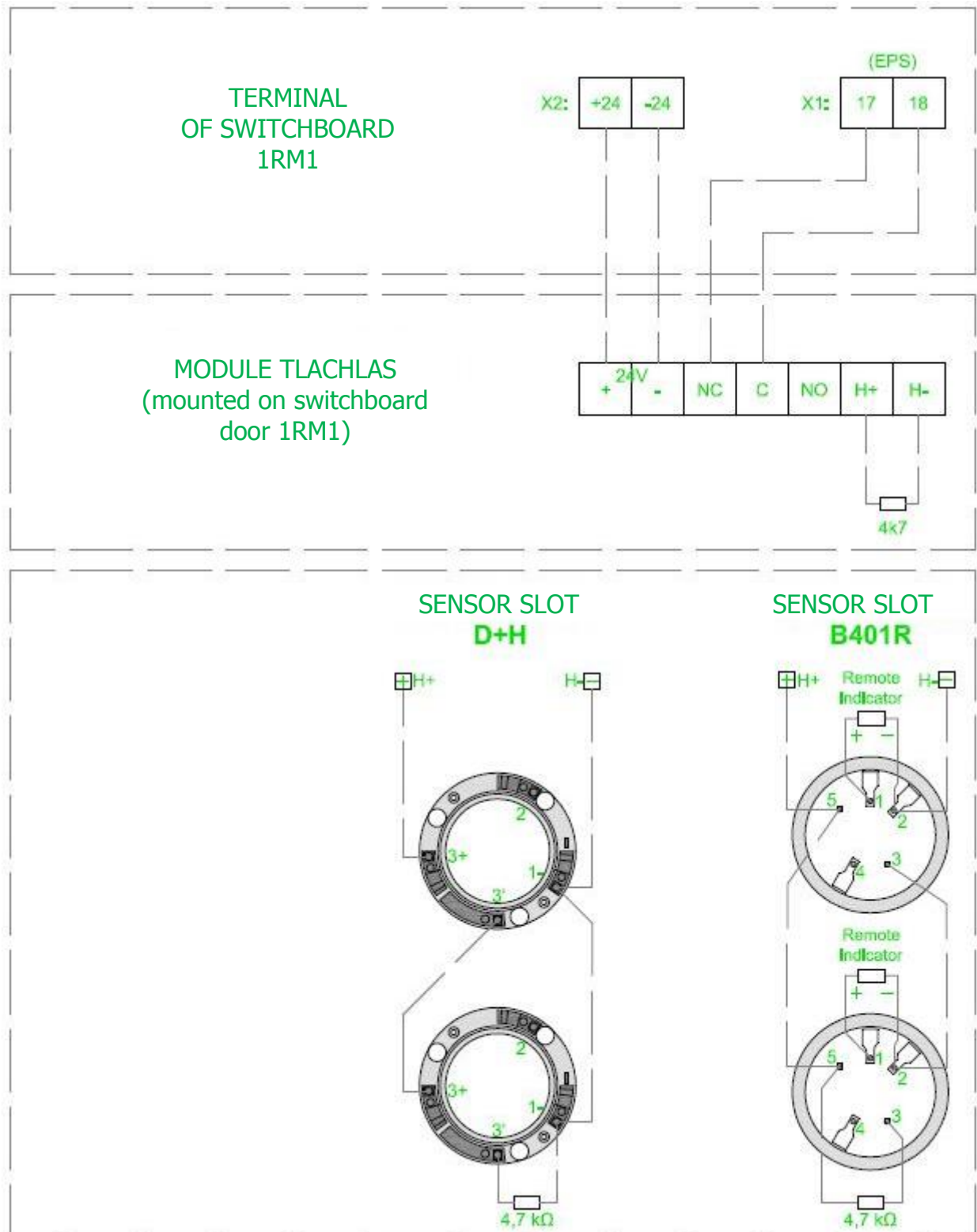



ELEKTROPOHONY spol. s r.o.

Závodí 234 • 744 01 Frenštát pod Radhoštěm - CZ

tel.: +420 556 880 611 • fax: +420 556 880 698

e-mail: info@epo.cz • <http://www.epo.cz>