



INSTALLATION GUIDELINES SGS





1. NOTIFICATION BEFORE INSTALLATION	1
2. CONTROL THE COMPLETENESS OF DELIVERY	2
3. BUILDING CONTROL BY A PARTICULAR MODEL KITS	6
4. INSTALLATION OF LOAD-BEARING ELEMENTS	7
5. INSTALLATION OF TRACK HOLDERS AND TRACK	8
5.1.Sliding doors – telescopic.....	10
6. ASSEMBLY OF DOOR SECTION	11
7. INSTALLATION OF DOORFRAME PROFILES	13
8. INSTALLATION OF STOPS	14
8.1 Single-sliding doors	14
8.2 Double-sliding doors	14
9. INSTALLATION OF OPERATING SYSTEMS	15
9.1 Electromagnetic brake system	15
9.1.1 Installation of counterweight bracket, brake, reverse pulley and door pull... 15	
9.1.1.1 Single-sliding doors.....	15
9.1.1.2 Double-sliding doors	16
9.1.2 Installation of counterweight and rope.....	20
9.1.2 Counterweight filling.....	21
9.2 Master electromagnetic drive	22
9.2.1 Installing motor bracket and reverse pulley with tightener	22
9.2.2 Installation of belt	23
9.2.3 Installation and setting optical controller	24
9.2.3.1 Single-sliding doors.....	24
9.2.3.2 Double-sliding doors	24
9.3 Electromagnetic anchor system	25
10. CONNECTION OF CONTROL PANEL	26
11. TRACK COVERING	27
13. GUARANTEE CONDITIONS	31





1. NOTIFICATION BEFORE INSTALLATION

Dear customer,

We are glad that you decided to fire sectional doors from Somat system Ltd.

Please read these instructions and follow them. It gives you important information about the safe installation and operation of your doors and specialized maintenance and repairs.

Professional service and careful maintenance significantly affects performance and usability of the device gate. Operating errors and improper maintenance lead to operational faults, which can be avoided. Your satisfaction and long-term operational reliability is ensured only when the professional operation and careful maintenance.

Important instructions:

- Follow the instructions in this manual
- Improper installation or improper maintenance the door could lead to life-threatening injuries. For your own safety check carried out by a qualified professional installation of company
- Transport sections of the door only on the special pallet
- The doors open and close horizontally. For this reason, ensure that the the door during operation in the area of the door not stay any people - especially children - and no objects
- The appliance the door, use only if it is in perfect condition. Equipment failure the door can lead to life-threatening injuries
- Ensure that all the checks, repairs and cleaning equipment can not operate the door by a third party
- Do not alter or remove any functional parts! This may cut out important safety components
- Do not install any additional components. All components are precisely adjusted to each other. Additionally, components may overload the the door structure and lead to life-threatening injuries

Working tools:

- Use only tools suitable for the installation of doors and related equipment

Prepare the following working tools:











- **Suitable lifting equipment (truck crane)**
- **Suitable lifting platform or scaffolding**
- **Drill**
- **Grinder**
- **Set of keys**
- **Optical leveling device**
- **Aku screwdriver**
- **Taps (for mounting on a steel structure)**





2. CONTROL THE COMPLETENESS OF DELIVERY





Before installation, remove the technical drawing package and packing list and verify that the shipment corresponds to the packing list.

1. Set of the brackets		
1.1.		Bracket
1.2.		Track holder
1.3.		Connector
1.4.		Counterweight
1.5.		Granulate sack
1.6.		Steel supporting rope
1.7.		4 pcs eye socket
1.8.		8 - 12 pcs cable clip
1.9.		Connecting material
2. Set of track		
2.1.		Track
2.2.		Connecting material
3. Labyrinths		
3.1.		Upper labyrinth
3.2.		2 pcs side labyrinth
3.3.		Connecting material







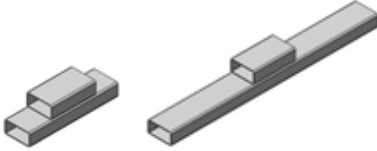





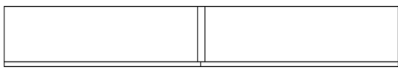

4. Door sections

4.1.		Door sections
4.2.		Washers on steel roller unit
4.3.		Top profile
4.4.		Threaded rods
4.5.		Top and bottom reinforcing profiles

5. Material for completion







5.1.		Bottom guide rollers
5.2.		Track stop
5.3.		4 ks floor stop
5.4.		F profile
5.5.		Track covers
5.6.		Connecting material

6. Controls

6.1.		Bracket
6.2.		Brake Linig (installed on 6.1)
6.3.		Console of pulley
6.4.		Pulley PVC (install on 6.3)
6.5.		Rope
6.6.		Door pull





6.7.		Console of motor
6.8.		Motor
6.9.		Reverse pulley with tightener
6.10.		Clamping plate
6.11.		Belt
6.12.		Pulley of magnet
6.13.		Magnet
6.14.		Counterpart of magnet
6.15.		Control panel Slidetronic or Slidetronic II or Blocktronic
6.16.		Connecting material
7. Additional equipment – according to specifics an order (e.g.)		
7.1.		Temperature sensor
7.2.		Somke sensor
7.3.		Combi sensor
7.4.		Siren with flash beacon
8. Mounting material – are delivered in standard bolts for mounting to the structure – can be ordered according to the type of supporting structure (walls, steel construction ...)		





Recommended anchors

Type of wall	Consoles	Profiles	Wall	Horizontal bar
Concrete	Wedge Anchor (10x90 or 12x110)	screw + anchor		
Steel	Screw + nut + washer	Tex 6,3		
Porotherm	Anchoring through the wall - distributing pads under the console	Fischer FUR		
Plynosilikat				





3. BUILDING CONTROL BY A PARTICULAR MODEL KITS

- The values you can find in the attached
- Mark the center of the opening
- Create-meter mark on both sides of the the door opening (must be horizontal to the ground)
- If either of greater dimensions than the doors according to the documentation. Doors can not be installed (less than or as large as in the documentation)

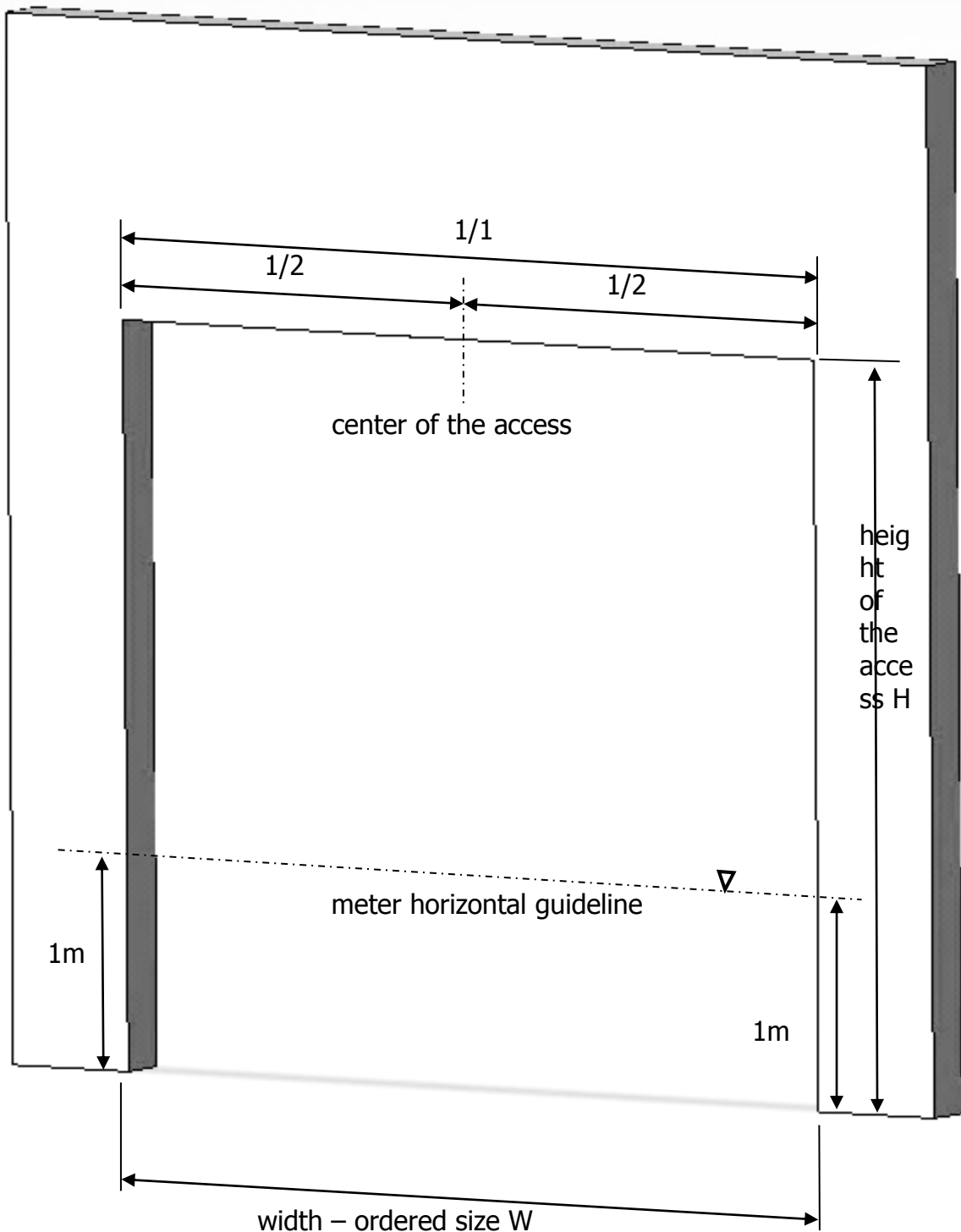



4. INSTALLATION OF LOAD-BEARING ELEMENTS

The brackets must be installed into the position shown in the drawings in the documentation.

1. Anchoring concrete anchors
2. Anchoring of bolts into the wall
3. Anchoring of anchors into the ceiling

- Single leaf console - console is anchored to the edge of the opening (340 mm from the hole)
- Spacing between brackets is 60 cm

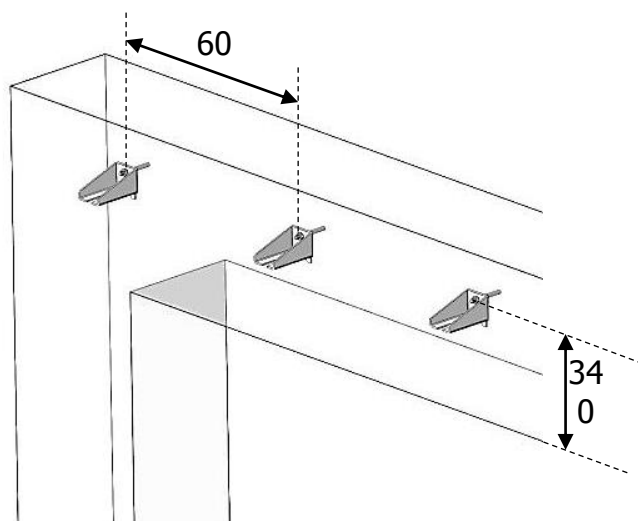

Anchoring by means of concrete anchors

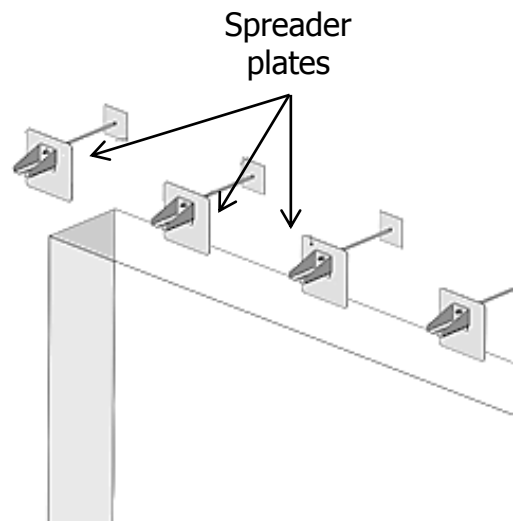

Anchoring by means of bolts through the wall

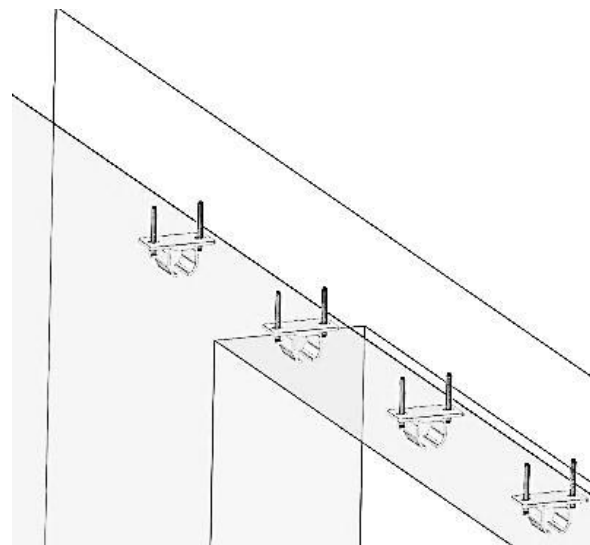

Anchoring to ceiling by means of concrete anchors

Note: Anchoring the brackets to the ceiling should be used only when installing into lower upper beam and then only into concrete or a steel structure.





5. INSTALLATION OF TRACK HOLDERS AND TRACK

The track holders should be mounted onto the track, then the bolts of the holders are slid, one after the other, into the slots of the mounting brackets. The track is supplied in the correct length that is made to measure according to the width of the door opening. The maximum length of one piece of track is 6 m. In case the track will be longer than 6 m, it is necessary to join the pieces of track using a connector.

1. Threads and screw the bracket and connectors on the rail
2. Lift rail and insert screws into the slot brackets in the console

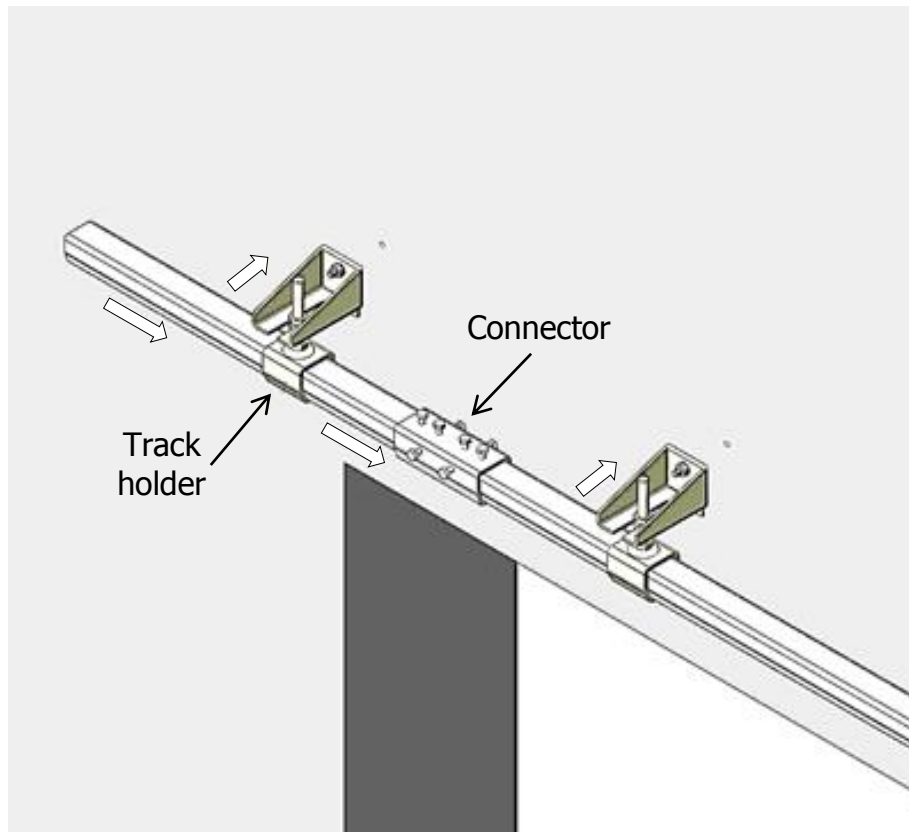



The track's installation must be consistent with the clearances specified in the documentation drawings with regard to:

- Distance of the track from the floor
- Distance of the track's axis from the wall (usually 80 mm)
- Distance between the end of the track and first bracket (controls C)

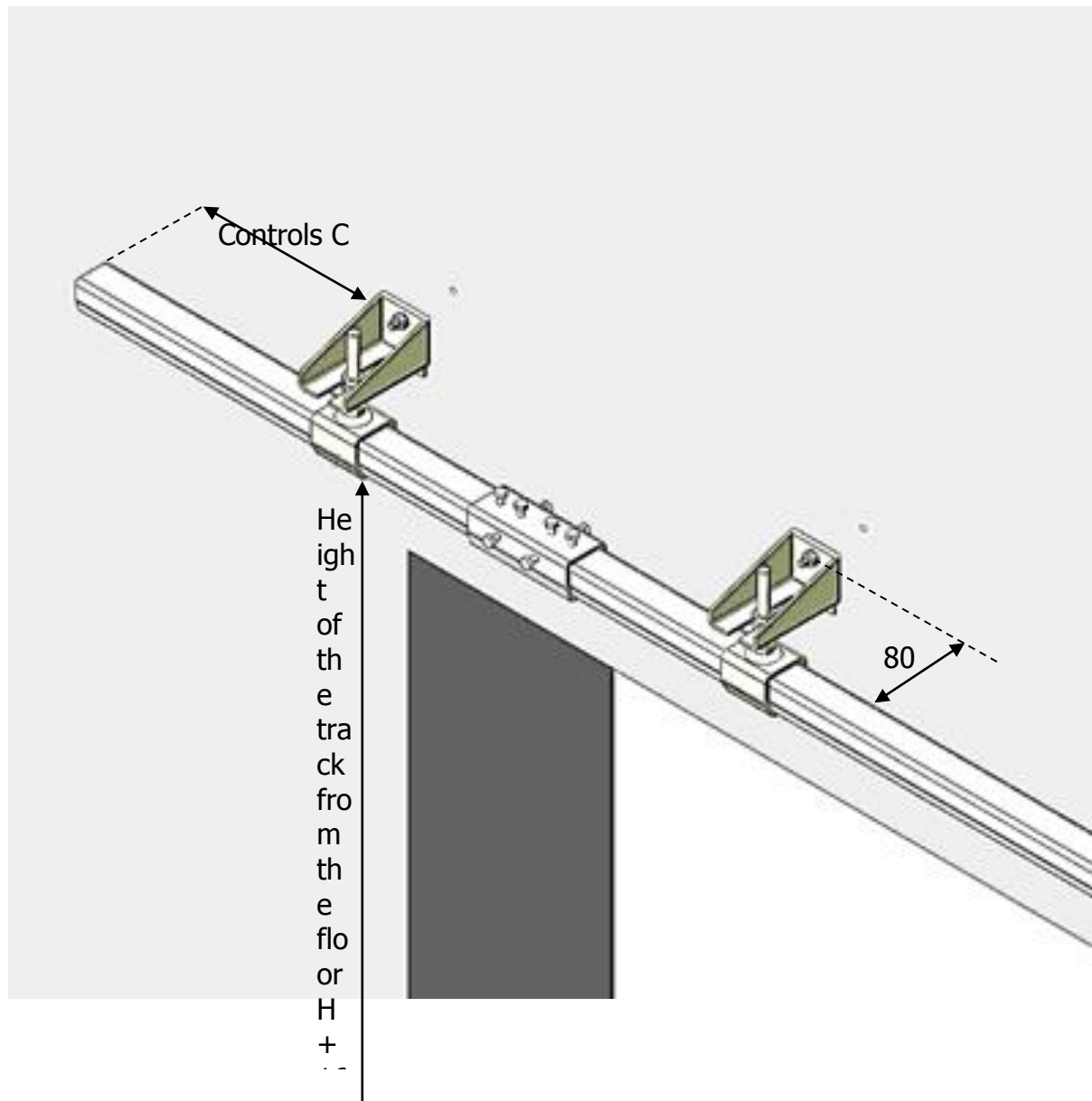



5.1. Sliding doors – telescopic

Suitable for places where is not enough width of space needed to open the entire wing (use of wider holes).

Installation procedure is the same, only to be mounted more than one track carrier to a larger console. Each door section is anchored to the upper beam with the counterpart labyrinth.

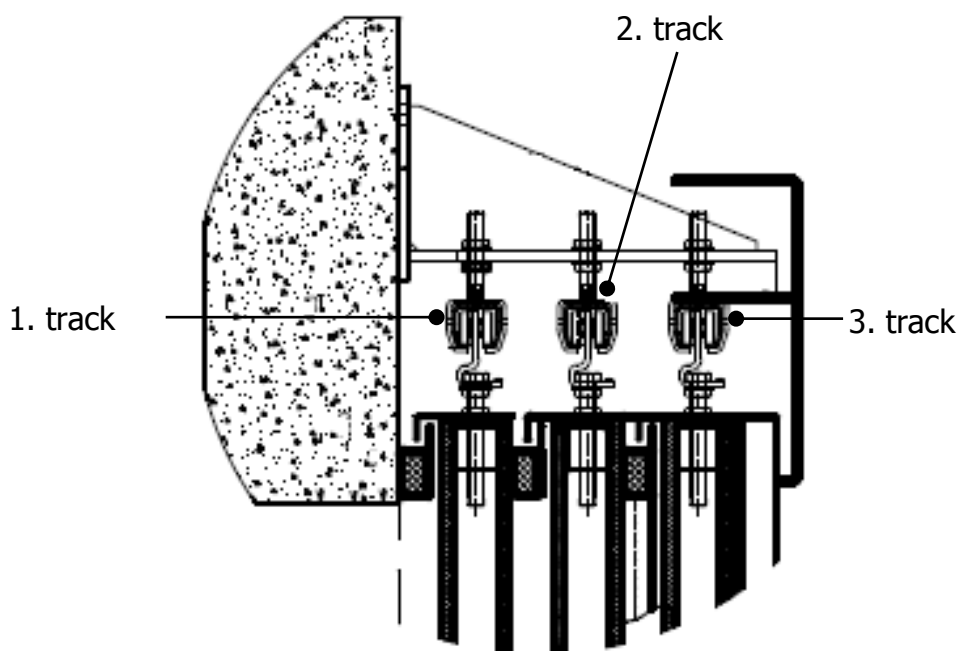
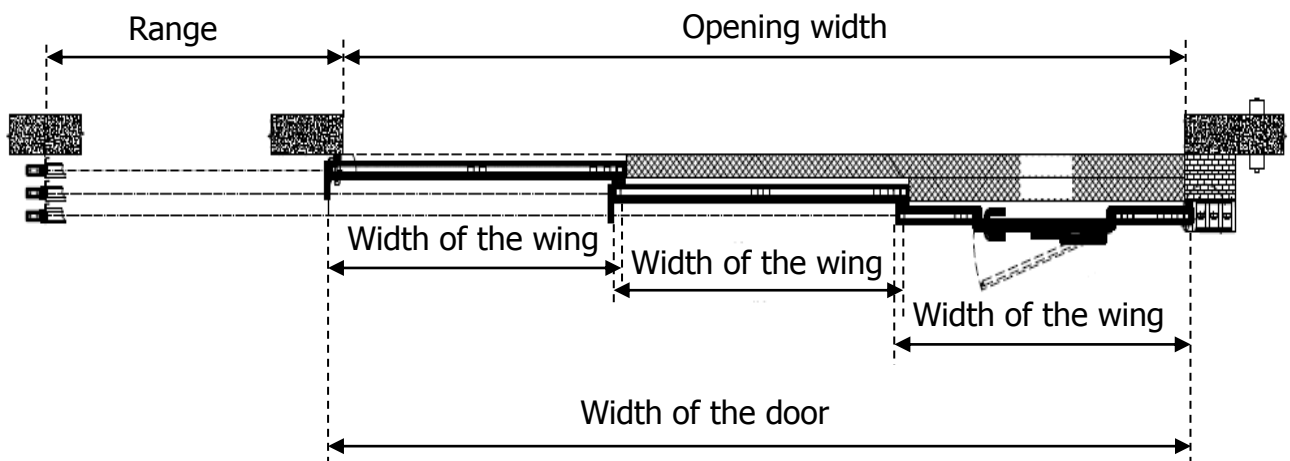



6. ASSEMBLY OF DOOR SECTION

- Mount the sections in the top profiles and steel rollers
- Hang up the sections to the tracks

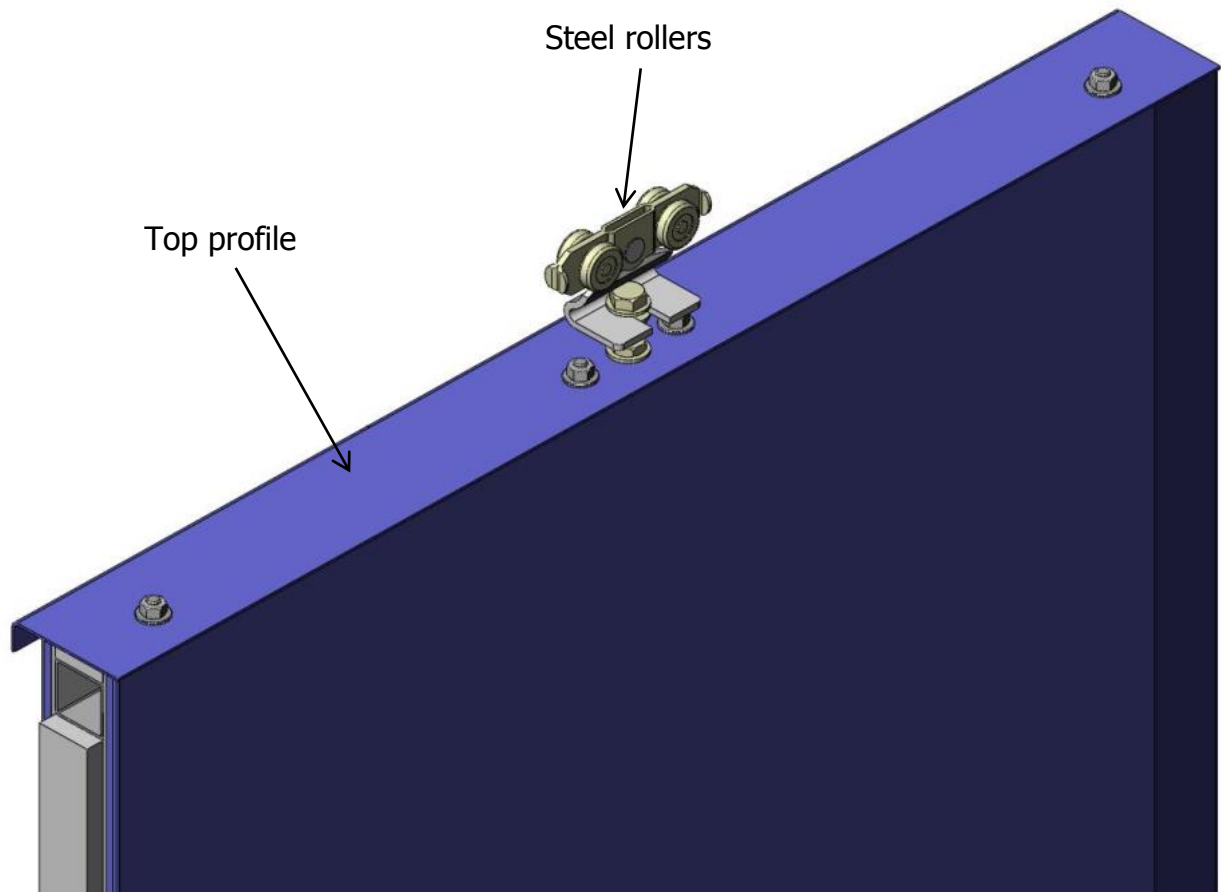



Before assembling individual door sections, it is necessary to insert the top and bottom reinforcing profiles.

- The individual sections must be joined together using threaded rods
- The holes for threaded rods must be closed off using plastic plugsto fit as well the labyrinths
- The height of the hanging door must be adjusted in order to set the gap under the door and floor to approximately 10–15 mm. The axis of the door should be set at the same distance from the wall as is the axis of the track holders (usually 80 mm, but depending upon the flatness of the wall)

inserting top a bottom reinforcing profiles

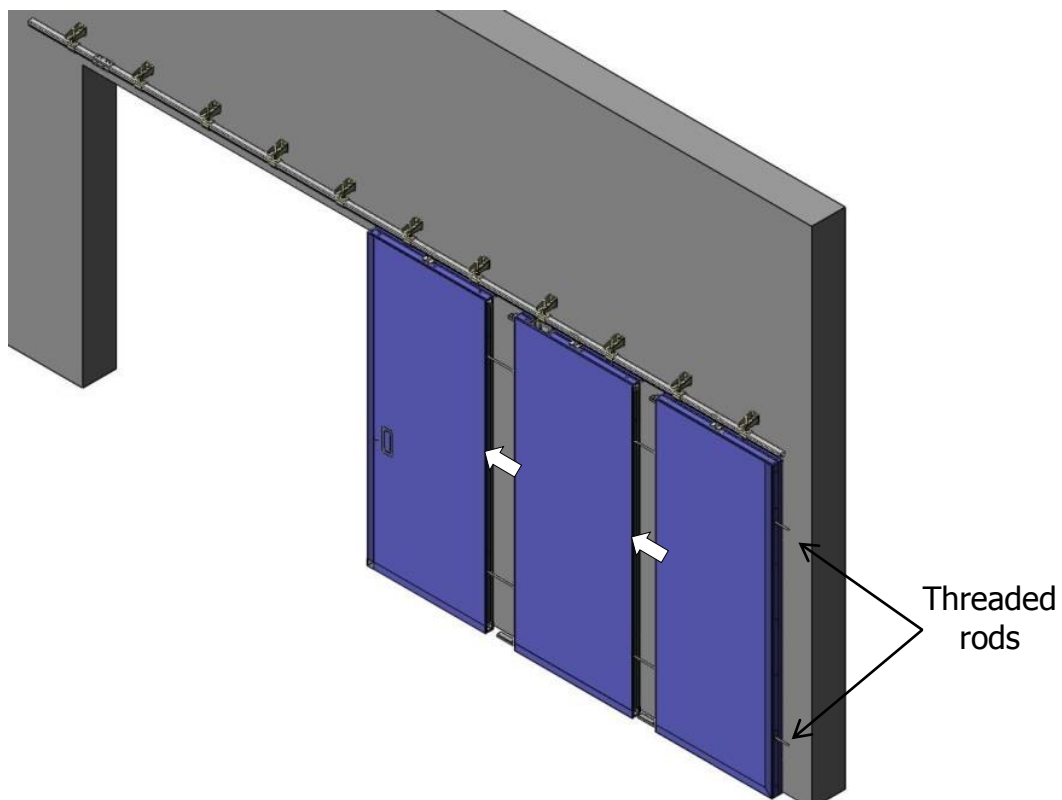
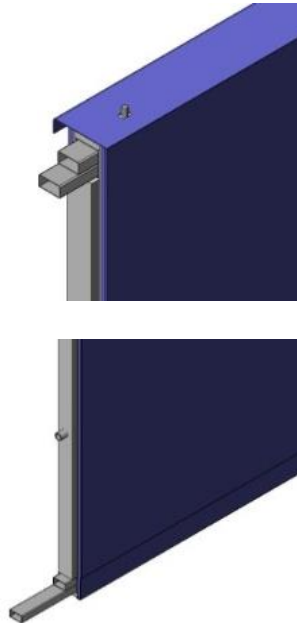



7. INSTALLATION OF DOORFRAME PROFILES

1. Labyrinth facing
2. Promat 45x25
3. Palusol 45x6

Anchor bolt as type of wall

- Expand
- Separate Palusol that covers the holes for anchoring
- Settle into positions
- Installation of anchors to the wall
- Stick Palusol that covers anchor bolts
 - paint Promat by contact adhesive

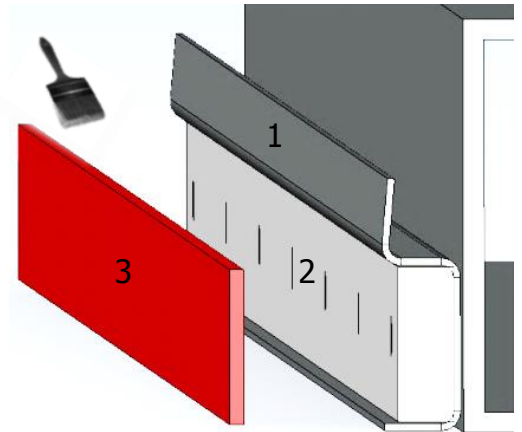

Note: In contrast to the single-sliding door shown above, a double-sliding door has two side profiles and no stop profile. In this case, a U-shaped cover for the counterweight is mounted. The cover's lower part is mounted to the wall and its upper part is attached to the mounted lower part using self-cutting screws.

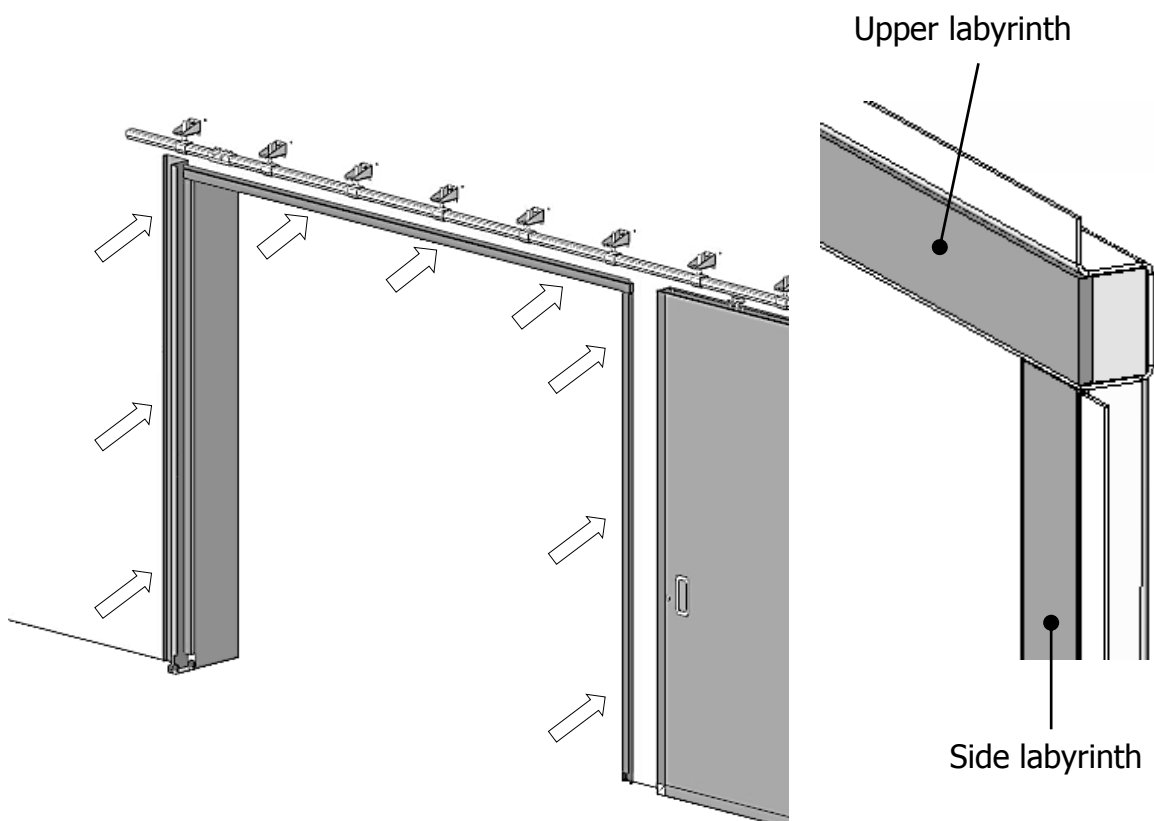

Overlap of profiles – top-down view





8. INSTALLATION OF STOPS

Anchoring by the relevant anchor cap

8.1 Single-sliding doors

- The bottom rollers are built into the stop profile (on the stopping side)
- Placement of front and back track stops of the track according to the position of the door in open and closed position
- Placement of the floor stop according to the position of the door in the open position (landing labyrinth his replaced by stop in the closed position)

8.2 Double-sliding doors

- Anchor the bottom guide rollers on both side doorframe profiles
- Placement of front and back track stops of the track according to the position of the door in open and closed position (both door panels separately – 4 pcs)
- Placement of the floor stop according to the position of the door in the open position (missing landing labyrinth for both sides)

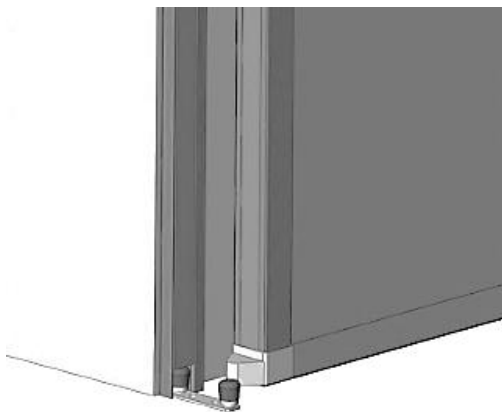

Installation of bottom rollers

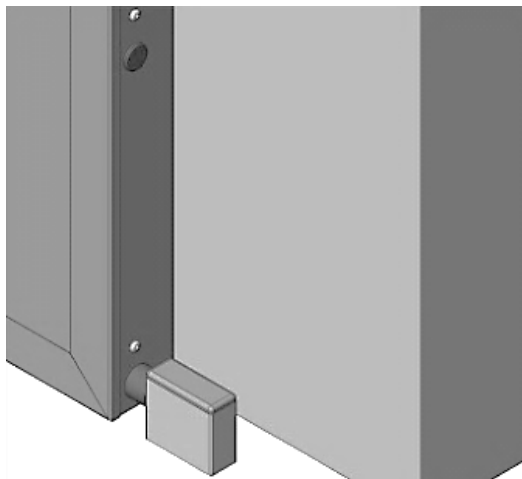
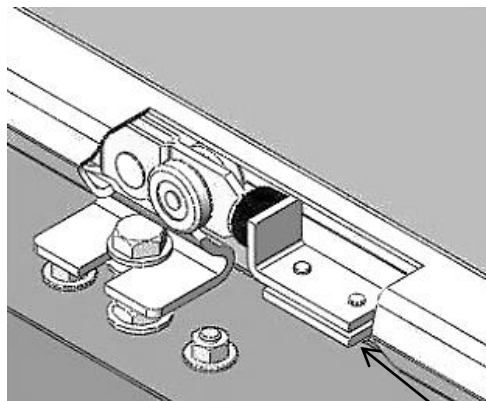

Installation of floor stop

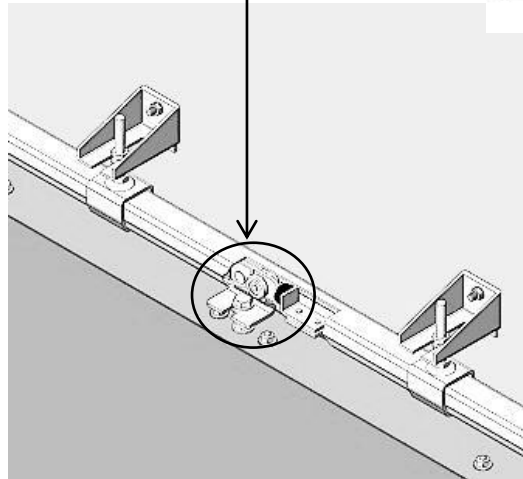

Installation of track stops



9. INSTALLATION OF OPERATING SYSTEMS

9.1 Electromagnetic brake system

9.1.1 Installation of counterweight bracket, brake, reverse pulley and door pull

9.1.1.1 Single-sliding doors

- The standard installation of the bracket for the counterweight and brake is at that end of the track where the stop profile is located. Only in a case, that there is not enough space on the stop profile side are the brake and counterweight brake installed on the other end of the track, and then they are replaced on the stop profile side by a reverse pulley
- The door pull is affixed using the same nuts as are holding the top profiles in place. It should be installed where two sections of door panel join, and at the end closest to the counterweight
- Stringing of the wire rope in two loops:
 - 1. loop eads from the door pull over the brake to the reverse pulley and back to the door pull. The loop should be tightened using the turnbuckle that is located between the door pull and the brake
 - 2. loop leads from the door pull over the pulley on the counterweight bracket, then through the counterweight pulley and back to the counterweight bracket
- The rope is connected to the door pull, turnbuckle and counterweight bracket by looping the rope end into an eye and fastening with wire rope clips (2 pcs per connection).



Brake with bracket



9.1.1.2 Double-sliding doors

- The brake and counterweight bracket are installed on the side of the counterweight cover (according to the drawings in the documentation). The bracket is affixed using a clamp joint. The system is similar for double-sliding doors
- Two door pulls are installed in the case of a double-sliding door (one for each side). On the side closer to the counterweight, the door pull is installed in the same way as for a single-sliding door, meaning that the bend is on the side away from the wall. On the other side, it is installed the other way around, meaning that the bend is on the side nearest to the wall.
- Stringing of the wire in two loops:
 - 1. loop leads through the door pulls of both sides. The door pull for the first side is connected to the line closer to the wall, and the second door pull is connected to the line further from the wall
 - 2. loop leads from the door pull over the pulley on the counterweight bracket, then through the counterweight pulley and back to the counterweight bracket
- The rope is connected to the door pull, turnbuckle and counterweight bracket by looping the rope end into an eye and fastening with wire rope clips (2 pcs per connection).

Brake with bracket

Counterweight pulley

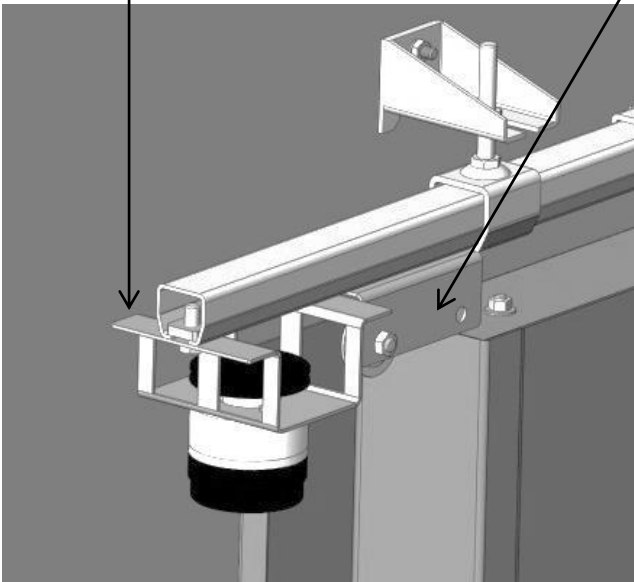

Placement of electromagnetic brake and bracket for the counterweight pulley

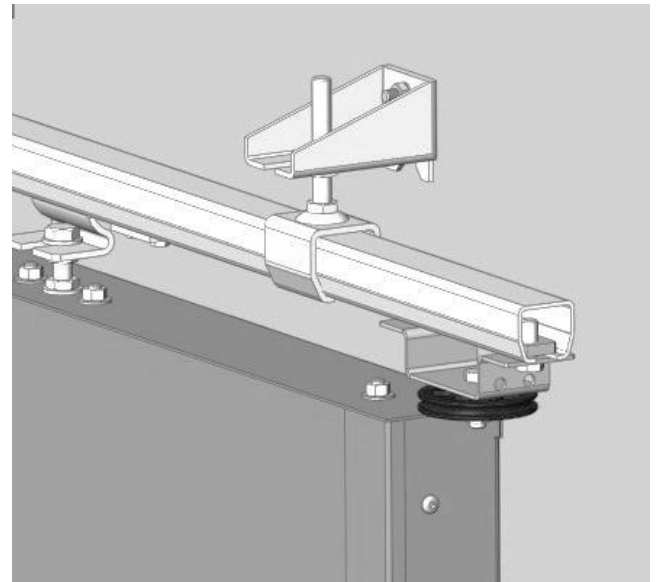

Placement of the reverse pulley



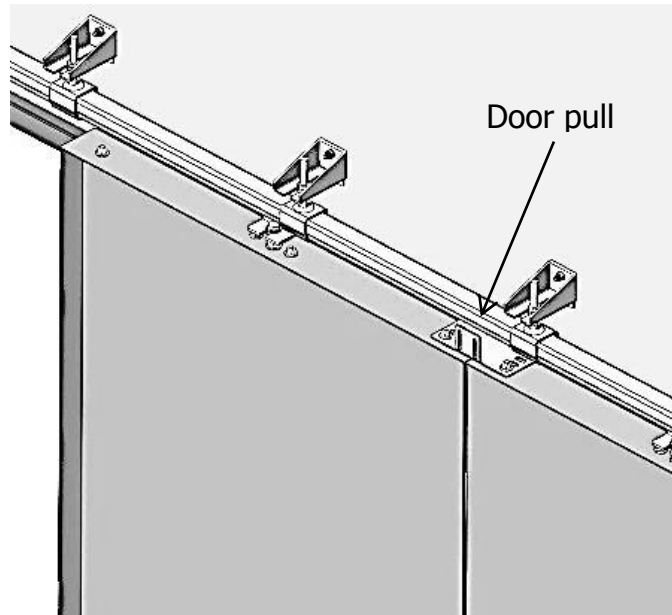

Placement of door pull

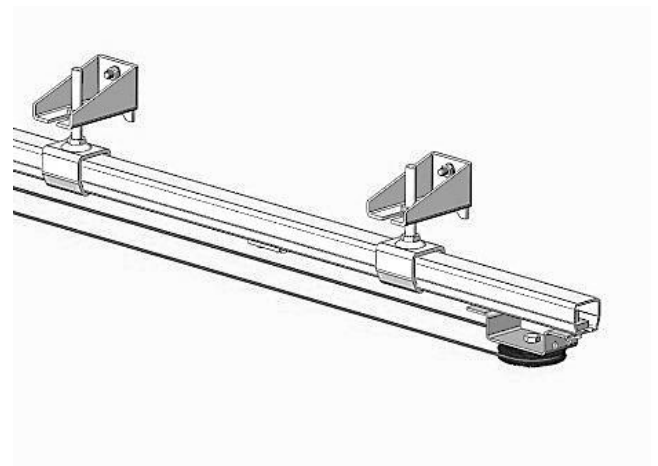
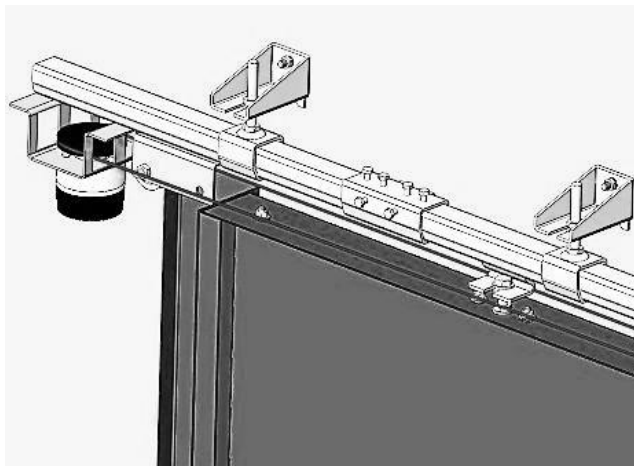

Brake and reverse pulley with wire rope under tension

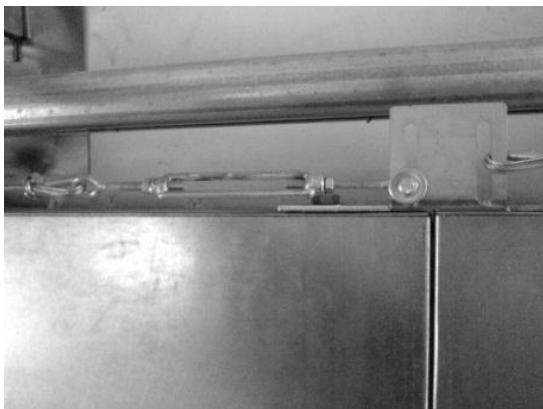

Door pull with screw turnbuckle





The direction of closing doors and moving wires - one more description of the installation (2 loops).

- A. 1. loop – connect door pull and one side of the rope through the eye socket and closes two terminals. Thread the rope through the pulley and pull the brake cable to the return pulley where rope stretch back through the pulley. Back to the other end of the cable, place the eye socket that you thread the tensioner, which is on the other side cleats before we started and fix the cable by two clips.
- B. 2. loop – Connect door pull and one side of the rope through the eye socket and closes two terminals. Roll off the cable to a counterweight via a pulley and thread the counterweight. Stretch the rope from the counterweight pulley and fix it on the counterweight pulley.

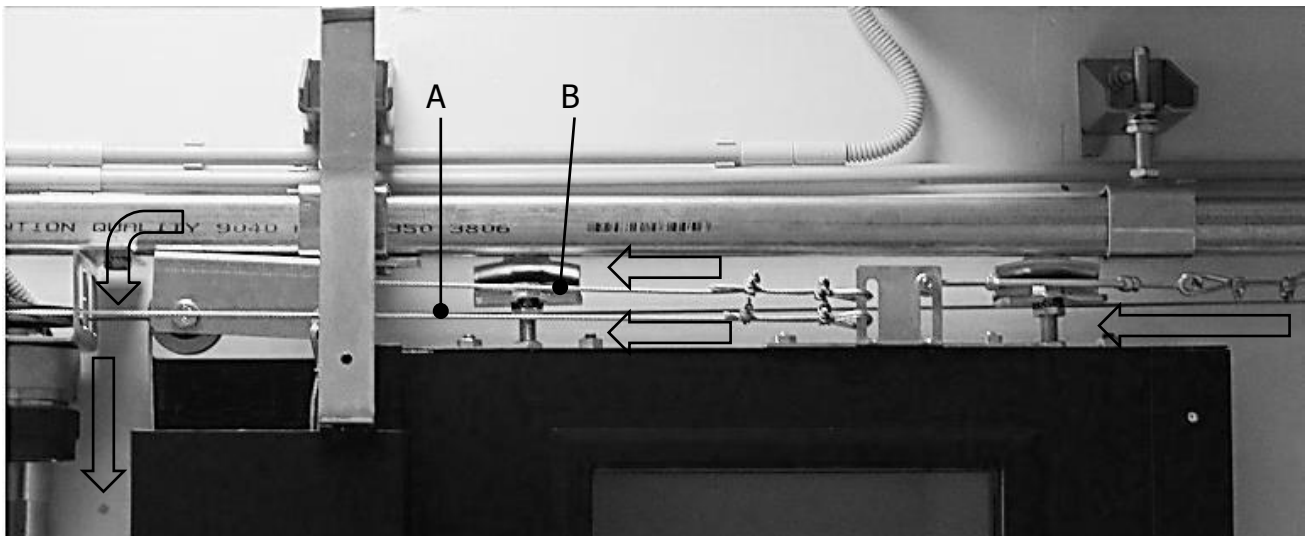



Setting of the brake

1. The pulley on the brake engages the door when the door is closing. When the door is opening, the pulley only spins on the void. If we want to pull the door slowed, remove the pulley, turn it and re-mount
2. The lower part of the body screw brake allows the speed brake doors. Release the metal latch and rotate the bottom part. The more the lower part of the body is released the brake will be slower and closing doors will be quickly.
3. Unscrew the lower part of the most 3 to 4 turns from a maximum screw - optimal settings
4. After setting the braking speed metal latch to secure the brake grooves

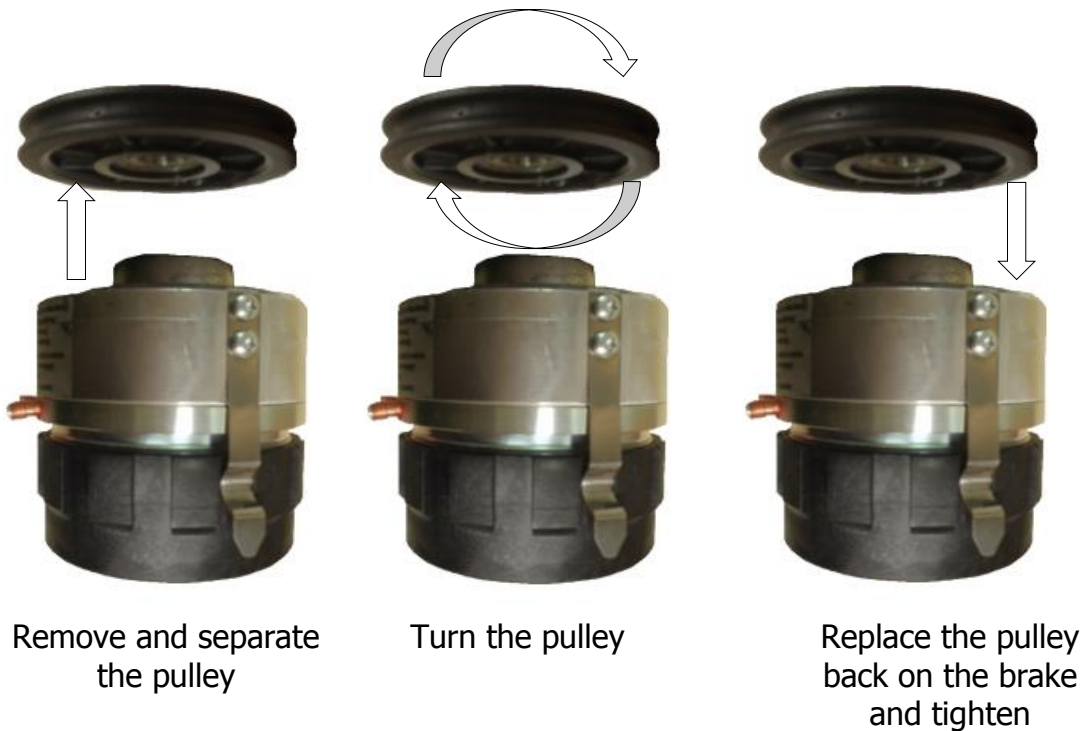
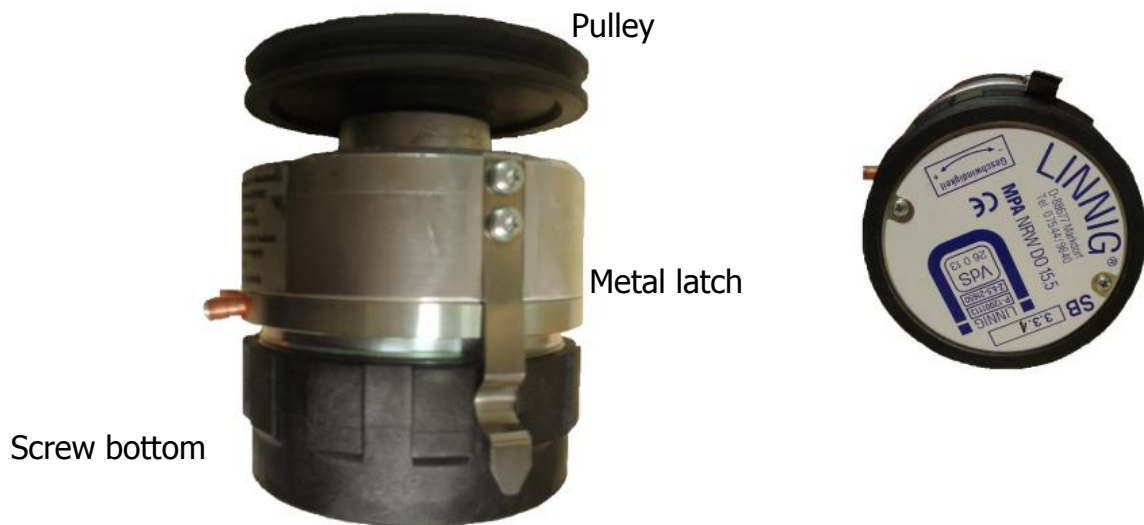



9.1.1 Installation of counterweight and rope

- Pull the rope to the counterweight pulley and thread it through the counterweight pulley
- Meanwhile empty counterweight pulls up

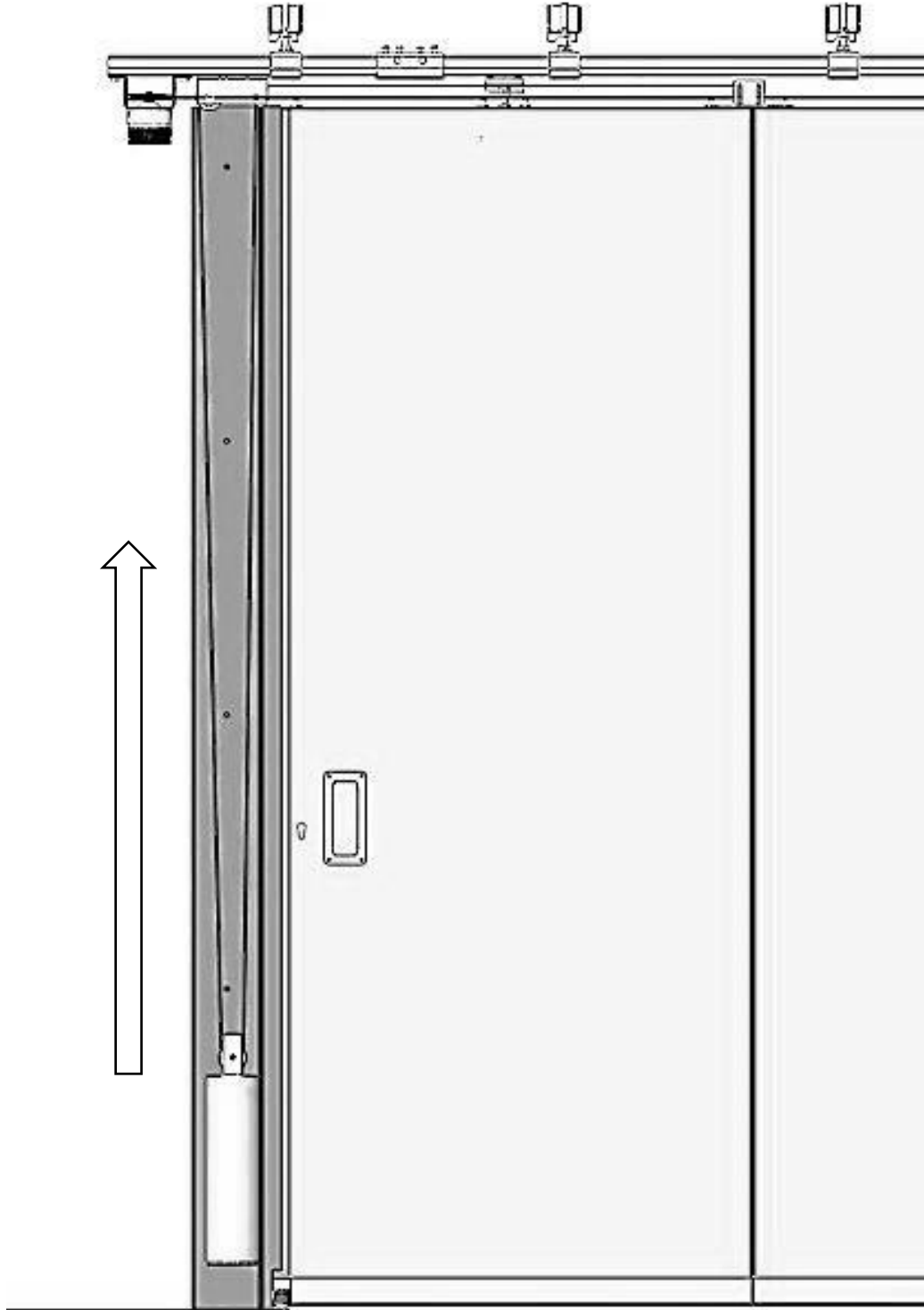



9.1.2 Counterweight filling

- Fill the counterweight by the sand or granulate, doors should be outweighed about 50 kg (difference of weight doors X counterweight). It should be adjusted according to doors resistance
- 1 sack weighs 25 kg of granulate

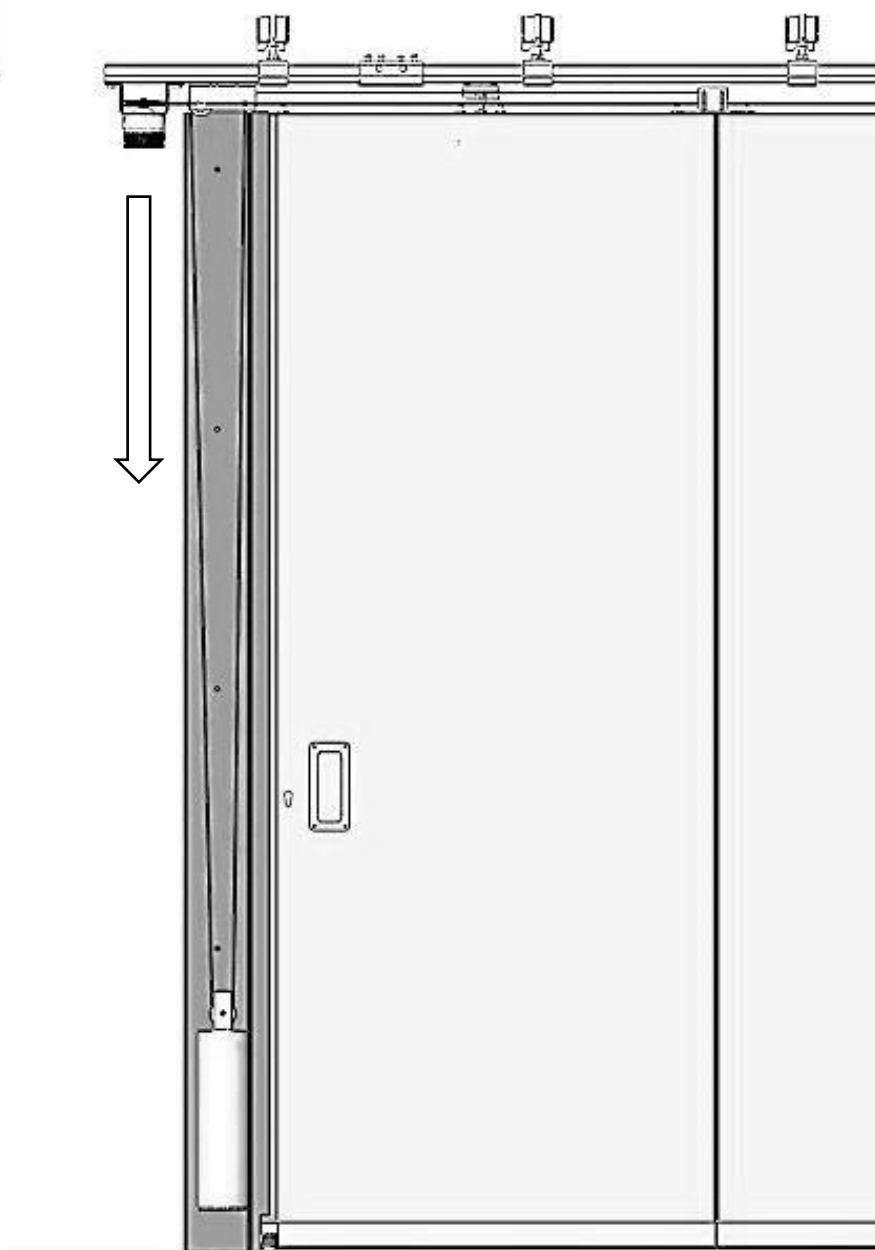
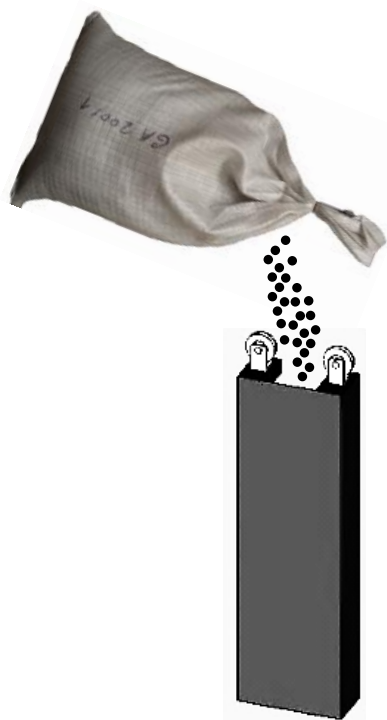



9.2 Master electromagnetic drive

9.2.1 Installing motor bracket and reverse pulley with tightener

- Place the motor bracket on the labyrinth landing side
- Reverse pulley with tightener put on the track next to the track holder and secure with six screws
- Mount the door pull (see section 9.1)

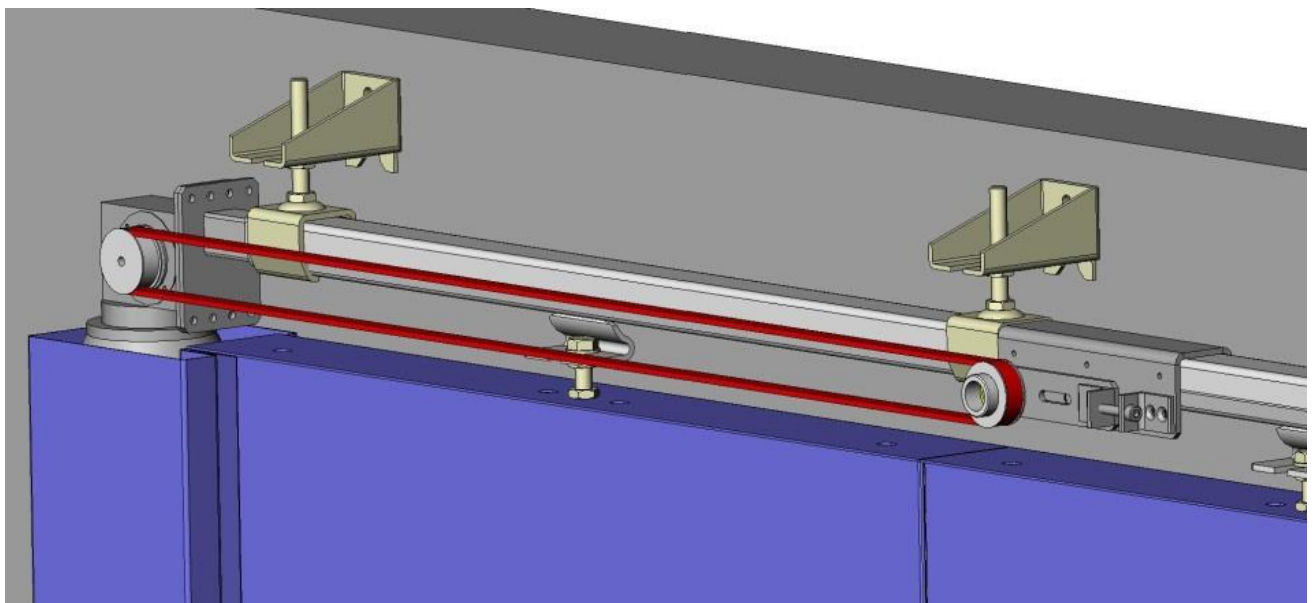

Motor bracket and reverse pulley with tightener



9.2.2 Installation of belt

The belt makes just one loop between the motor pulley and the reverse pulley through the door pull. In case of larger doors (4x4 m and more) supporting sliders should be installed to help carry the belt.

- The belt should be tightened using the tightener on the reverse pulley to a maximum force of 300 N
- Both ends of the belt are connected with the door pull using a clamping plate

In the case of a double-sliding door, each panel has its own door pull: the first door pull is connected to the bottom of the belt's loop, and the second door pull is connected to the top of the belt's loop.

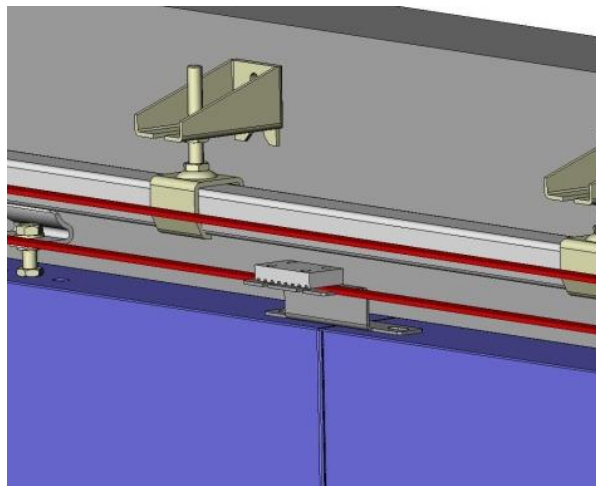

Door pull with clamping plate

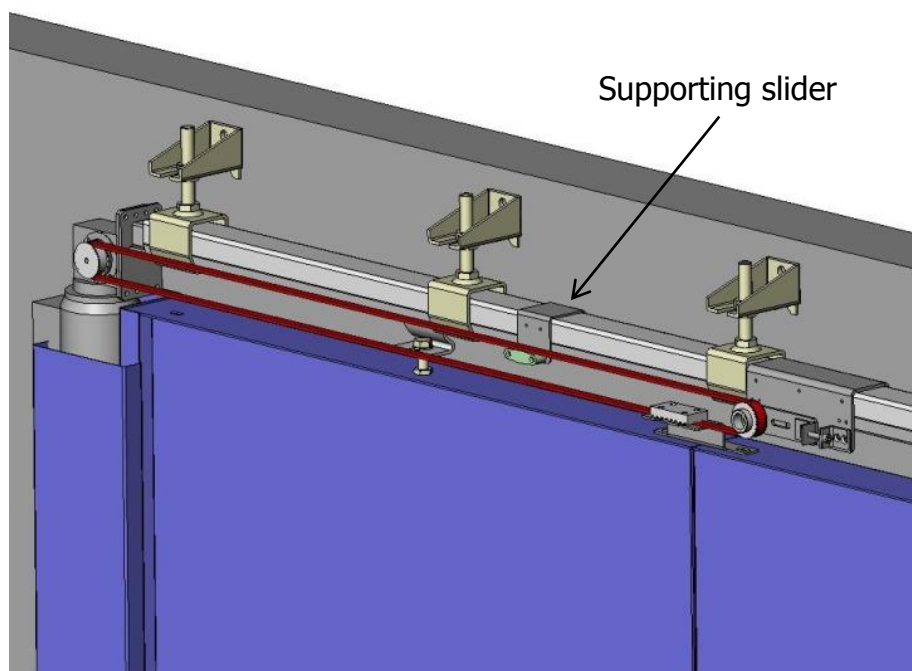

Belt with supporting slider





9.2.3 Installation and setting optical controller

9.2.3.1 Single-sliding doors

- It is necessary to set up the optical controller so that its ray is directed to the reflector that is built into the door panel

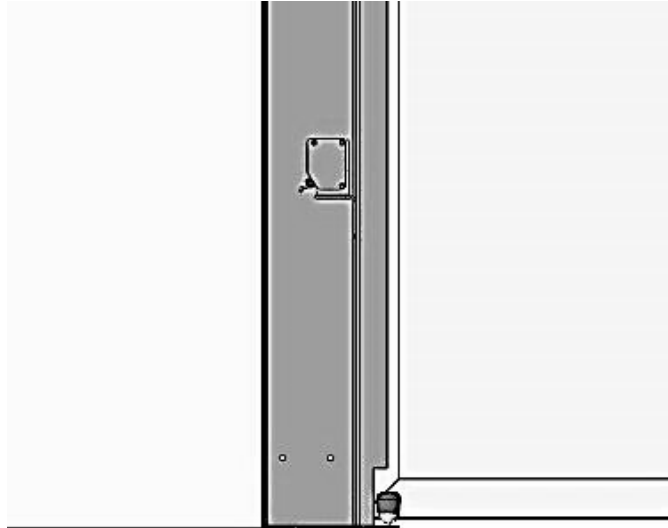

9.2.3.2 Double-sliding doors

- The optical controller and reflector are installed on special wall brackets (approximately 500 mm from the floor)

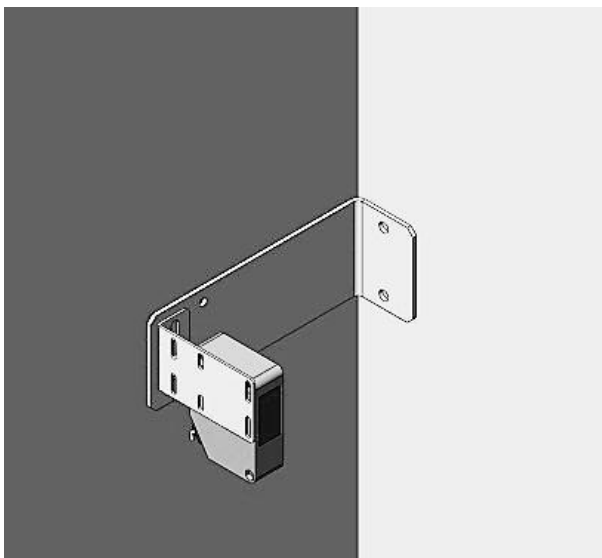

Optical controller

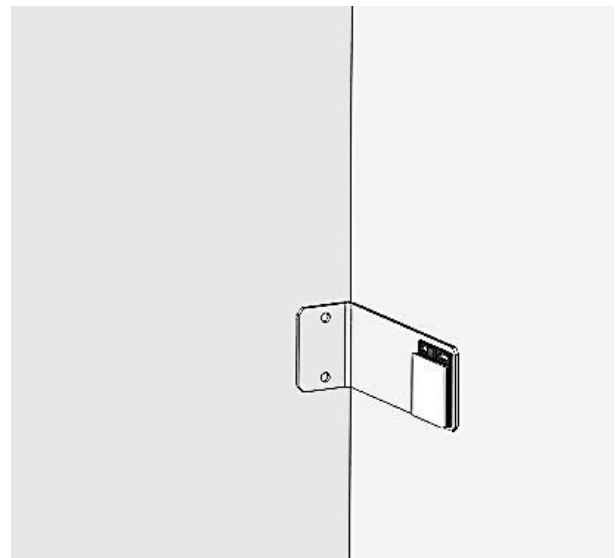

Reflector





9.3 Electromagnetic anchor system

In this system, a magnet holds the door in the open position. The door closes by the help of a counterweight or inclined track at the signal of the central detection system (in the case of an inclined track, the height of the track in the middle is in the documentation drawings. The recommended slope is 1 cm/m.)

- Clamp connection is used to install the magnet onto the track
- The counterpart is installed on the door panel using screws
- The magnet must be adjusted both vertically and horizontally according to the position of the door

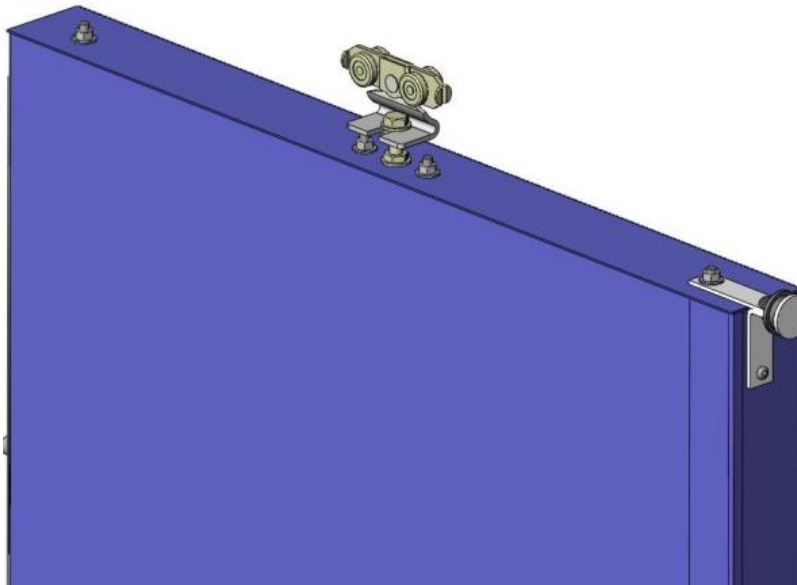

Counterpart of magnet

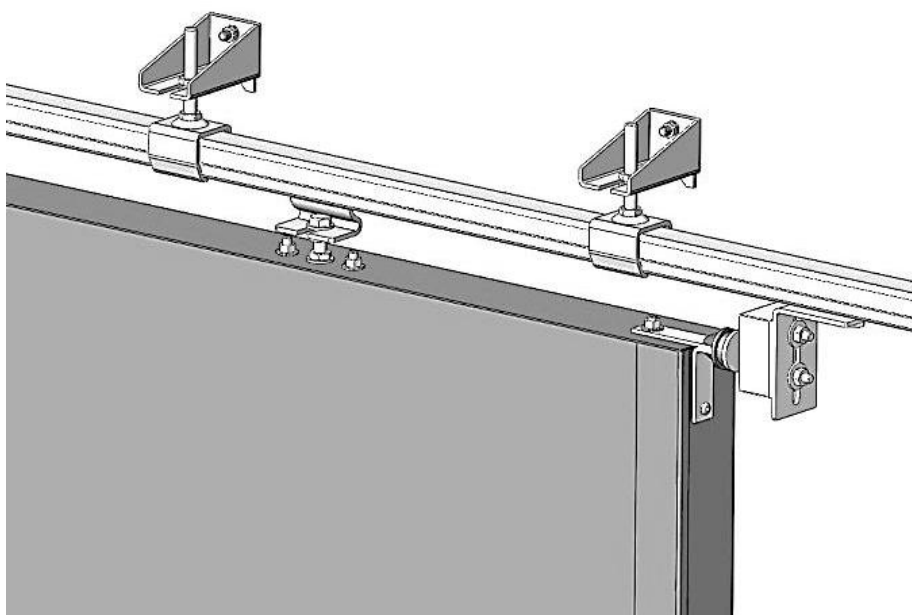

Magnet installed on track + counterpart on door panel





10. CONNECTION OF CONTROL PANEL

Viz. Manual electrical control panel

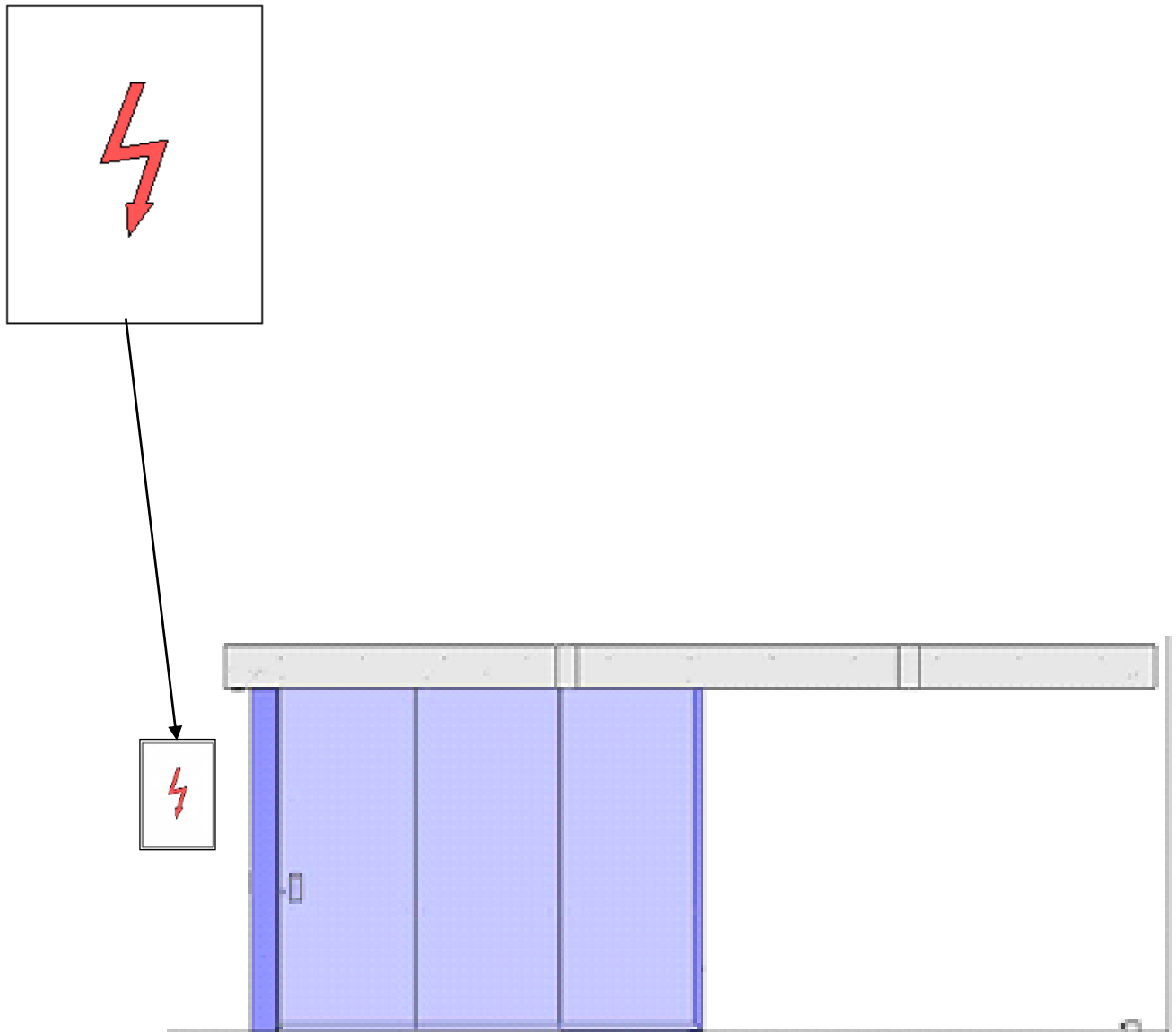



11. TRACK COVERING

- Install the cover of the range labyrinth and covers of the tracks.

The track covering is installed on F-profiles, which are placed under the lower nuts on the track holders. Any gaps between individual cover sections should be overlaid by connecting covers.

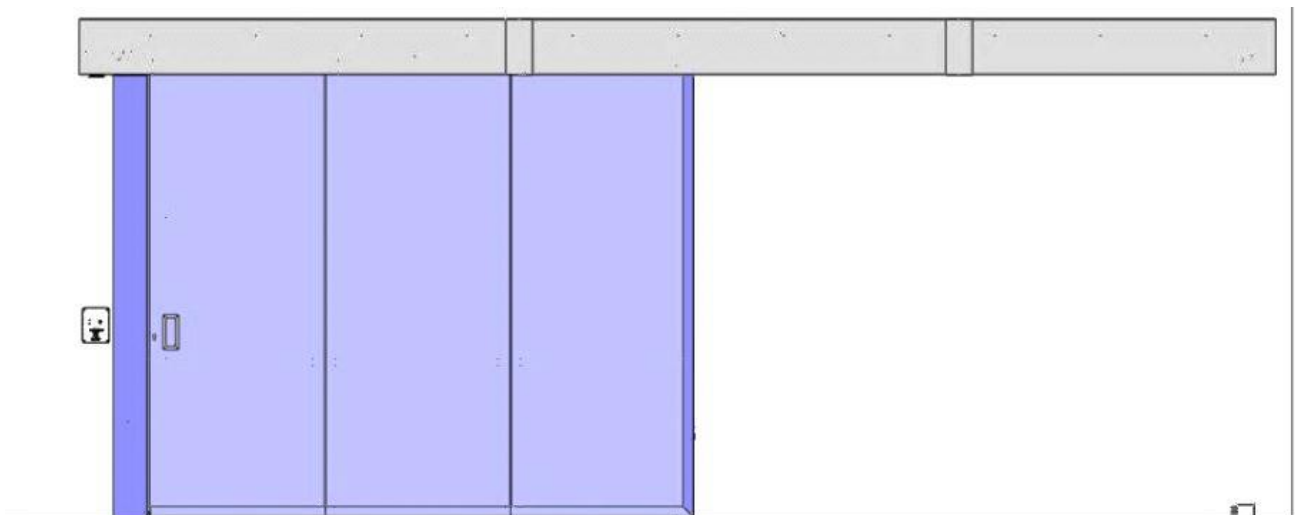
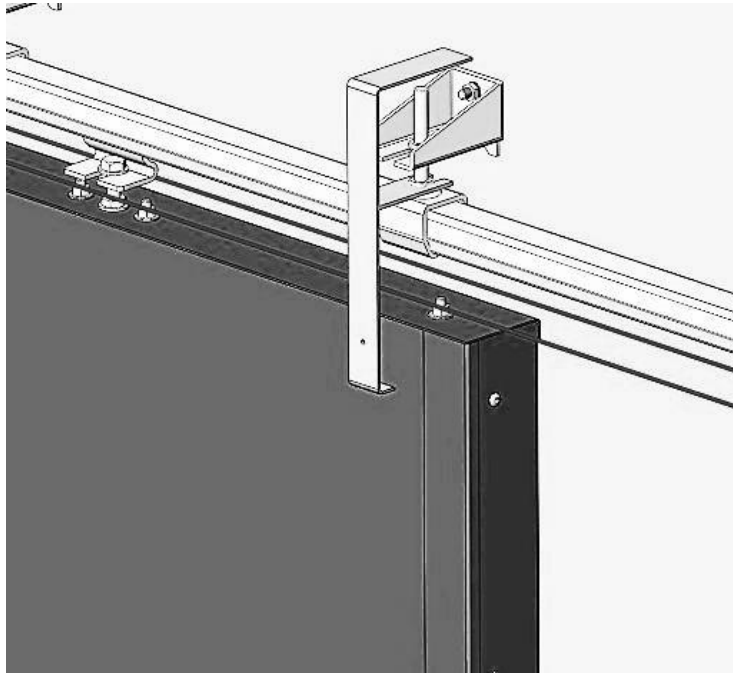



12. ANNEX FOR MOUNTING SGS TOUR

Technology of fire shutters SGS TOUR consists of universal parts that allow you to change the orientation of shutters. From left to right version and from right to left version.

Currently standard design of SGS TOUR shutter:

- EM brake
- Lacquered metal RAL 7035
- 2x recessed handle
- Control panel SLIDETRONIC II

12.1 Differences of components SGS TOUR:

SECTIONS AND TOP PROFILE

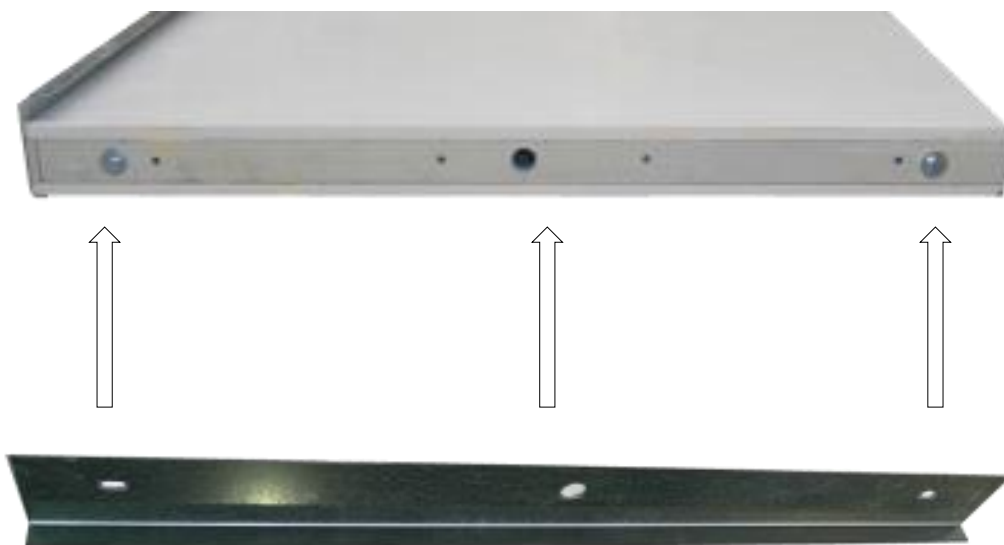

Holes for mounting top profile are at sections away from the edge of the section as far to put them mounted steel roller, without having to drill more holes on the construction.





SIDE PROFILE



upper part of section



The side profile is cut from both sides.
If the construction has changed
the orientation of shutter, just turn
the profile and reattach the section.

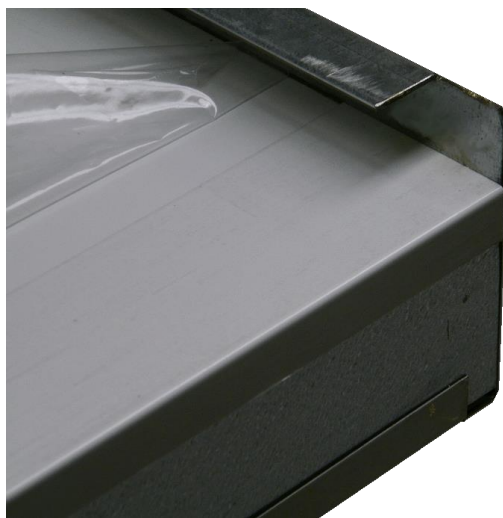

Lower part of section





STOP PROFILE



Stop profile is usable for both orientations of fire shutter, without any further treatment.



Stop profile thorn
(replacement for bottom rollers)



Hobnailed section with the guide
hole for thorn

VERTICAL WALL LABYRINTH

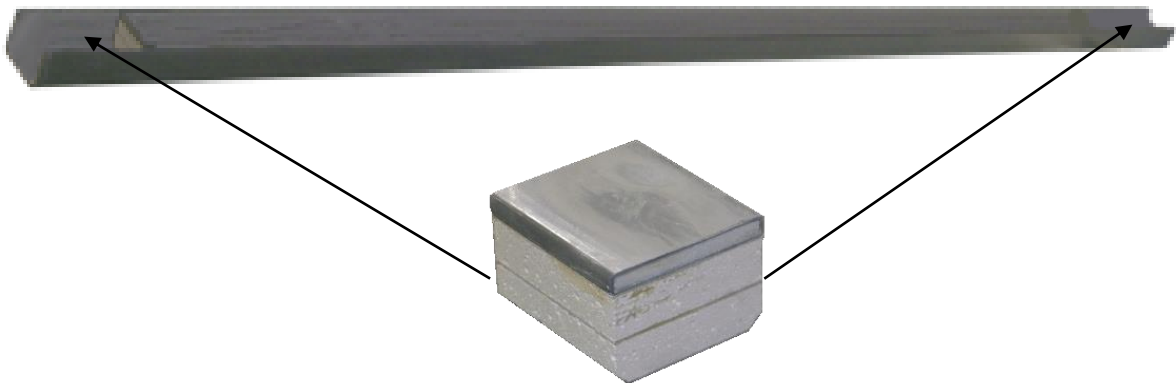

Universal cube lining. When assembling the structure according to the orientation glued cube on top of the opening lining.





13. GUARANTEE CONDITIONS

Guarantee and product liability shall cease if you make without the consent of the manufacturer or let design changes made unqualified installation or in contravention with mounting regulations. Furthermore, the manufacturer does not accept responsibility for the unintentional or careless operation of the actuator and equipment and unqualified maintenance of the doors and balance. Supplies and materials subject to wear, such as batteries or lights are also excluded from warranty and liability claims.

In addition to the statutory warranty dealer arising from the purchase contract provided by the manufacturer depending on the type of guarantee on the drive for 2 years from date of purchase. The application of the guarantee does not extend the guarantee. For replacement parts and additional editing the warranty period is six months but at least the initial warranty period.

Guarantee claims are only valid for the country in which the door was purchased. The goods must come from channels of distribution, which was established by us. The warranty claim is valid only for damage to the subject matter of the contract. Purchase document is valid as proof of warranty claim.

During the warranty period, remove all the shortcomings of a product. That is demonstrably consequence the material or manufacturing errors. We are committed to the defective goods free of charge to according to our choice of harmless goods to replace, repair or replace inferior quality. Guarantee is excluded for damages if they happen under the following assumptions:

- Improper connections and built-in
- Improper commissioning and unprofessional staff
- Mechanical damage in an accident, fall, crash
- Damage due to negligence or wanton destruction
- Normal wear and tear
- Repairs carried out by unqualified persons
- Use of parts of foreign origin

Removing or defaced product number replaced parts become the property of the manufacturer.

